

# FINITE ELEMENT ANALYSIS

Guide through to ANSYS Workbench v16.2

The screenshot displays the ANSYS Workbench v16.2 interface. The main window shows a 3D model of a mechanical part with a rainbow-colored stress distribution. The software's menu bar and toolbars are visible at the top. The Outline tree on the left shows the project structure:

- Project
  - Model (A4)
    - Geometry
    - Coordinate Systems
    - Symmetry
    - Mesh
  - Static Structural (A5)
    - Analysis Settings
    - Displacement
    - Pressure
  - Solution (A6)
    - Solution Information
    - Total Deformation
    - Equivalent Stress
    - Normal Stress
    - Maximum Principal Stress

The Details of "Total Deformation" table is shown at the bottom left:

Details of "Total Deformation"	
<b>Scope</b>	
Scoping Method	Geometry Selection
Geometry	All Bodies
<b>Definition</b>	
Type	Total Deformation
By	Time
<input type="checkbox"/> Display Time	Last
Calculate Time History	Yes
Identifier	
Suppressed	No
<b>Results</b>	
<input type="checkbox"/> Minimum	4.9169e-004 mm
<input type="checkbox"/> Maximum	2.7535e-002 mm
<b>Information</b>	

Other views include a cylindrical part, a truss structure, and a U-shaped part, all showing stress distributions. The background features a large, colorful stress distribution on a curved surface.



*Finite Element Analysis Method using*

*ANSYS Workbench v16.2*

Step-by-Step Guide...

# *Finite Element Analysis Method using ANSYS Workbench v16.2*

Step-by-Step Guide...

## **Credits and Copyright**

Written by: Bc. Syllignakis Stefanos  
[sylst3f@gmail.com](mailto:sylst3f@gmail.com)

Main Editor: Ing. Petr Vosynek, Ph.D  
[petr.vosynek@gmail.com](mailto:petr.vosynek@gmail.com)

Review and Editor: Ing. Marek Benešovský  
[\\*\\*\\*\\*\\*@vutbr.cz](mailto:*****@vutbr.cz)

## **Preface**

The presented material was created within the Erasmus+ project of the student Stefanos Syllignakis under the leadership of Petr Vosynek. It is basically support material for the subject 6KP and its English version 6KP-A (basics of computational modeling using finite element method) taught in the Institute of Solid Mechanics, Mechatronics and Biomechanics, Faculty of Mechanical Engineering, Brno University of Technology.

Computer labs of 6KP and 6KP-A are composed of active exercises under the current interpretation of the fundamentals associated with the type of elements and also from a separate project for a group of students. The texts were made in two versions, for the computing open\_source system Salome\_Meca (C\_A) and for computing system ANSYS Workbench v16.2.

## Table of Contents

Credits and Copyright .....	4
Preface .....	4
<b>INTRODUCTORY .....</b>	<b>9</b>
General Information .....	9
The Design Modeler .....	10
Basic Mouse Functionality .....	11
Selection Filters.....	11
Selection Panes .....	12
Graphic Controls .....	12
Additional Mouse Controls .....	12
Understanding Cell States.....	13
i. Typical Cell States .....	13
ii. Solution-Specific States.....	13
iii. Failure States .....	14
3D Geometry.....	15
Bodies and Parts .....	15
Boolean Operations .....	15
Feature Type .....	16
Feature Creation .....	17
<b>CHAPTER_I: CHILD SWING .....</b>	<b>19</b>
1.1 Problem Description .....	19
1.2 Workbench GUI.....	20
1.3 Preparing Engineering Data .....	21
1.4 Create Geometric Model .....	22
1.4.1 2D and 3D Simulations.....	22
1.4.2 More on Geometric Modeling .....	22
1.5 Divide Geometric Model Into Finite Elements .....	24
1.6 Set Up Loads and Supports .....	25
1.7 Solve the Finite Element Model.....	27
1.8 Viewing the Results.....	27
1.9 Second Part of Our Task.....	28
<b>CHAPTER_II: BEAM SYSTEM.....</b>	<b>32</b>
2.1 Problem Description .....	32
2.2 Start-Up.....	33
2.3 Create Body.....	34
2.4 Create Cross-Section .....	38
2.5 Start-up “Mechanical” .....	39

2.6 Generate Mesh .....	39
2.7 Specify Boundary Conditions .....	40
2.8 Specify Loads.....	40
2.9 Set up Solution Branch and Solve the Model .....	41
2.10 View the Results .....	41
<b>CHAPTER_III: PLATE .....</b>	<b>43</b>
3.1 Problem Description .....	43
3.2 Start-Up.....	44
3.3 Creating the 2D Geometry Model .....	44
3.4 Set Up Mesh Controls .....	47
3.5 Set Up Supports, Loads .....	48
3.6 Set Up Solution Outcome Branch .....	48
3.7 View the Results .....	49
3.7.1 Perform Simulations .....	50
3.8 Modify the Model .....	51
3.8.1 Set Up New Supports, Loads.....	52
3.8.2 Set Up New Mesh Controls.....	52
3.8.3 View the Results .....	52
3.9 Structural Error .....	53
3.10 Finite Element Convergence .....	54
3.11 Stress Concentration.....	55
3.11.1 View the Path Results .....	56
<b>CHAPTER_IV: SHAFT.....</b>	<b>57</b>
4.1 Problem Description .....	57
Examples before beginning our task .....	57
Shaft Description .....	58
4.2 Start-Up.....	59
4.3 Create Body.....	59
4.3.1 Getting back to the Modeling.....	61
4.4 Set Up Mesh Controls .....	62
4.5 Set Up Supports, Loads .....	63
4.6 Set Up Solution Outcome Branch .....	63
4.7 View the Results .....	64
4.7.1 Activating 3D View.....	65
4.9 Stress Concentration Factor .....	67
4.9.1 Hand Calculations VS Computational Calculations of Stress Concentration .....	68
Hand Calculations .....	68
Computational Calculations.....	68

Solving the Equation .....	68
4.10 Redefining Mesh .....	69
<b>CHAPTER_V: LEVEL OF GEOMETRY .....</b>	<b>70</b>
5.1 Problem Description .....	70
Car Chassis Description .....	71
i. Beam Elements .....	73
5.2.i Start Up .....	73
5.3.i Create Body .....	73
5.4.i Set Up Mesh Controls .....	76
5.5.i Set Up Supports, Loads .....	77
5.6.i Set Up Solution Outcome Branch .....	78
5.7.i View the Results .....	78
ii. Solid Elements .....	79
5.2.ii Start Up .....	79
5.3.ii Create Body .....	79
5.4.ii Set Up Mesh Controls .....	81
5.5.ii Set Up Supports, Loads .....	82
5.6.ii Set Up Solution Outcome Branch .....	82
5.7.ii View the Results .....	83
iii. Surface Elements .....	84
5.2.iii Start Up .....	84
5.3.iii Create Body .....	84
5.4.iii Set Up Mesh Controls .....	86
5.5.iii Set Up Supports, Loads .....	87
5.6.iii View the Results .....	87
iv. Type of Elements Comparison .....	88
<b>CHAPTER_VI: TUNING FORK .....</b>	<b>89</b>
6.1 Problem Description .....	89
6.2 Start Up .....	90
6.3 Create Body .....	90
6.4 Set Up Mesh Controls .....	93
6.5 Set Up Supports, Loads .....	93
6.6 View the Results .....	95
6.7 Modify Model .....	96
i. Changing Material .....	96
ii. Changing the Dimensions .....	97



---

*INTRODUCTORY*

---

## General Information



[Reference](#) --> Autodesk Network Article.

- # The ANSYS Workbench represents more than a general purpose engineering tool.
  - It provides a highly integrated engineering simulation platform.
  - It supports multi physics engineering solutions,
  - It provides bi-directional parametric associativity with most available CAD systems.
  
- # These tutorials are designed to introduce you to
  - The capabilities, functionalities and features of the ANSYS Workbench.
  - The nature and design of the ANSYS Workbench User Interface.
  - The concepts of ANSYS Workbench Projects and related engineering simulation capabilities.
  - The integrated nature of ANSYS Workbench technology.
  - The power of the ANSYS Workbench in using applied parametric modeling and simulation techniques to provide quality engineering solutions.

## The Design Modeler

File Management.

Image Capture.

Undo/ Redo of Modeling Operations.

Geometry Selection and Filtering.

Display Manipulation and Control.

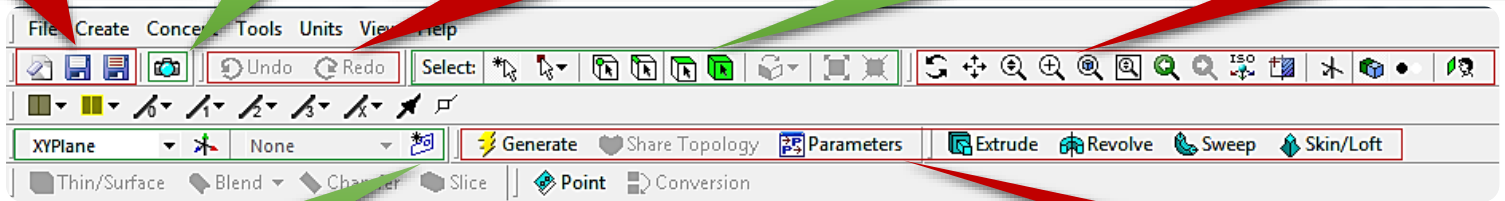

Plane and Sketch Management.

Depicts Modeling Operations.

3D Geometry Creation and Parameters.

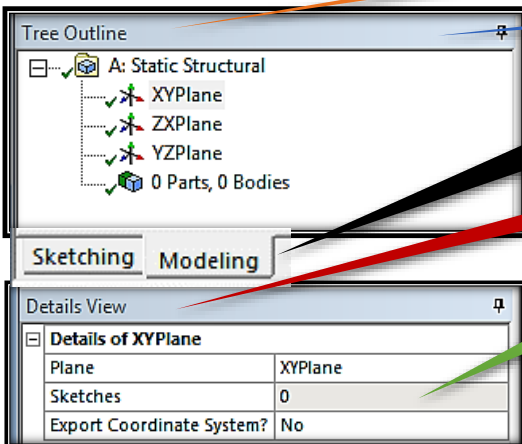

Supports Editing of Modeling Operations.

Modeling and Sketching Mode Switching.

Supports Viewing of Modeling Details.

Allows Editing of Model Details.

Provides Access to Sketching Tools.

Supports Sketch Creation and Modification.

Supports Viewing of Sketching Details.

Supports Editing of Geometry and Features.

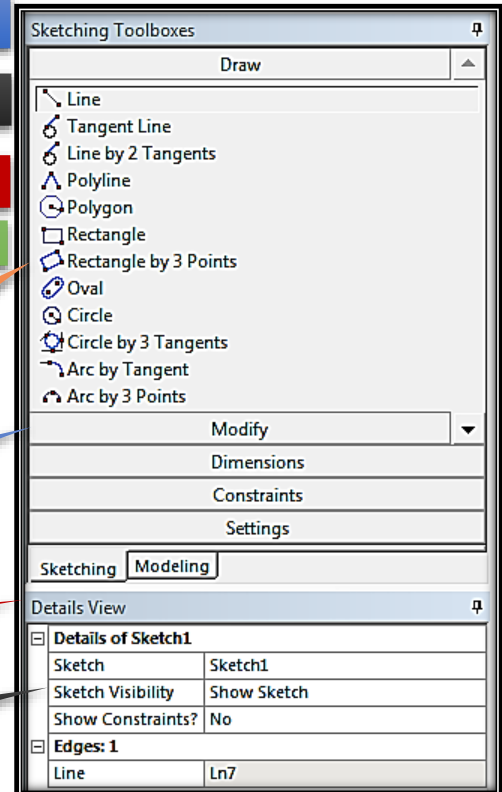

Sketching Toolboxes

Draw

Line  
 Tangent Line  
 Line by 2 Tangents  
 Polyline  
 Polygon  
 Rectangle  
 Rectangle by 3 Points  
 Oval  
 Circle  
 Circle by 3 Tangents  
 Arc by Tangent  
 Arc by 3 Points

Modify

Dimensions

Constraints

Settings

Sketching Modeling

Details View

Details of Sketch1	
Sketch	Sketch1
Sketch Visibility	Show Sketch
Show Constraints?	No
Edges: 1	
Line	Ln7

## # Sketching Mode:

- Provides for the creation of sketches using standard or user defined model coordinate systems.
- Supports the creation of 3D parametric solids from 2D sketches.

## # Modeling Mode:

- Provides tools for the creation and modification of 3D parts and models.
- Tracks and supports modification of modeling operations.

## Basic Mouse Functionality

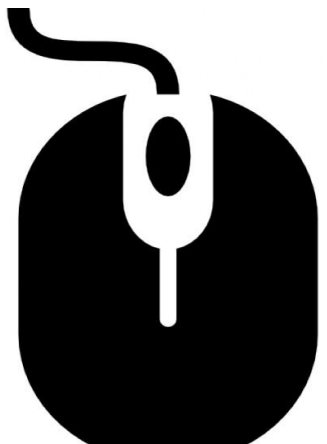

**# Left Mouse Button. [LMB]**

- Geometry Selection.
- Ctrl+ LMB → Adds/ Removes Selected Entities.
- Hold LMB and Sweep Cursor → Continuous Selection.
- Press+ Hold → "Paint Select".

**# Right Mouse Button. [RMB]**

- Open Pop-Up Context Menus.

**# Middle Mouse Button. [MMB]**

- Free Rotation.

## Selection Filters

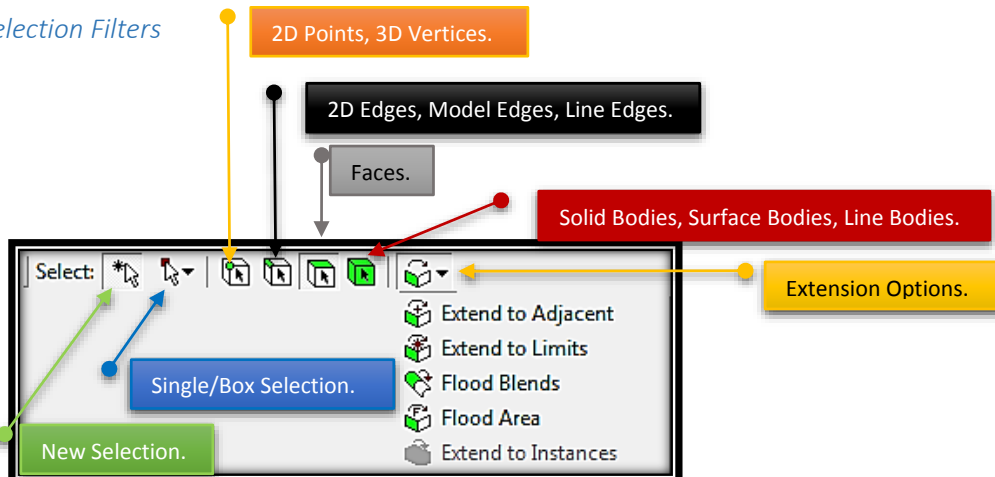

2D Points, 3D Vertices.

2D Edges, Model Edges, Line Edges.

Faces.

Solid Bodies, Surface Bodies, Line Bodies.

Extension Options.

Single/Box Selection.

New Selection.

Extend to Adjacent

Extend to Limits

Flood Blends

Flood Area

Extend to Instances

- # Model features are identified by graphically picking them using the left mouse button.
- # Feature selection is done by activating one of the selection filters from the menu bar or from pop-up menus using the right mouse button.
- # In selection mode, the cursor changes to reflect current selection filter.
- # Adjacent and Flood Selections extend selections to adjacent areas. Additional information can be found in the ANSYS Workbench Help (documentation).
- # Selection filters can also be set using pop-up menus (right mouse button in the Model View).

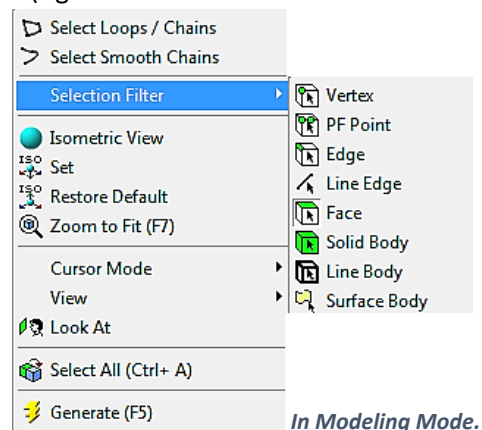
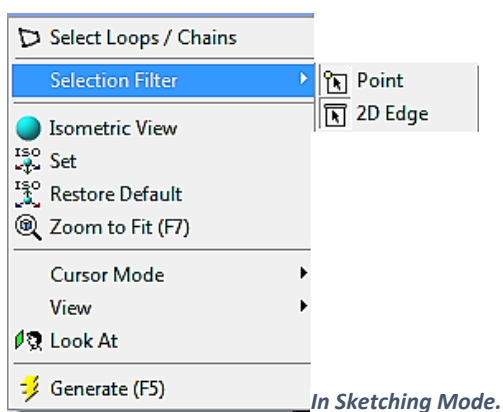

Selection Panes

- # Selection Panes allow selecting hidden geometry (lines, surfaces, etc.) after an initial selection.
  - o In assemblies only panes are color coded to match part colors.
  - o Multi-select techniques apply to selection panes as well.
- # Initial left mouse click.

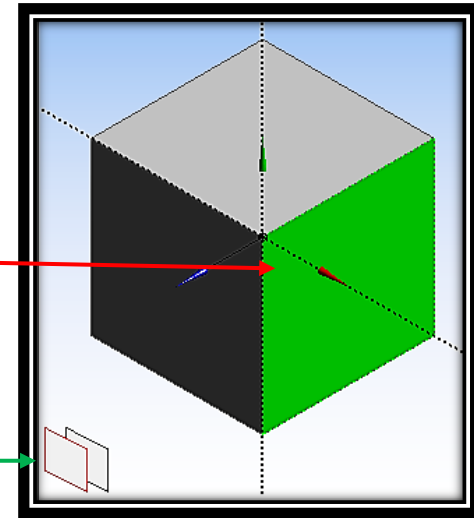

**Note:** Each plane represents an entity (surface, edge, etc.) that an imaginary line would pass through, starting from the initial mouse click location and proceeding into the screen away from the viewer in the normal viewing direction.

Graphic Controls

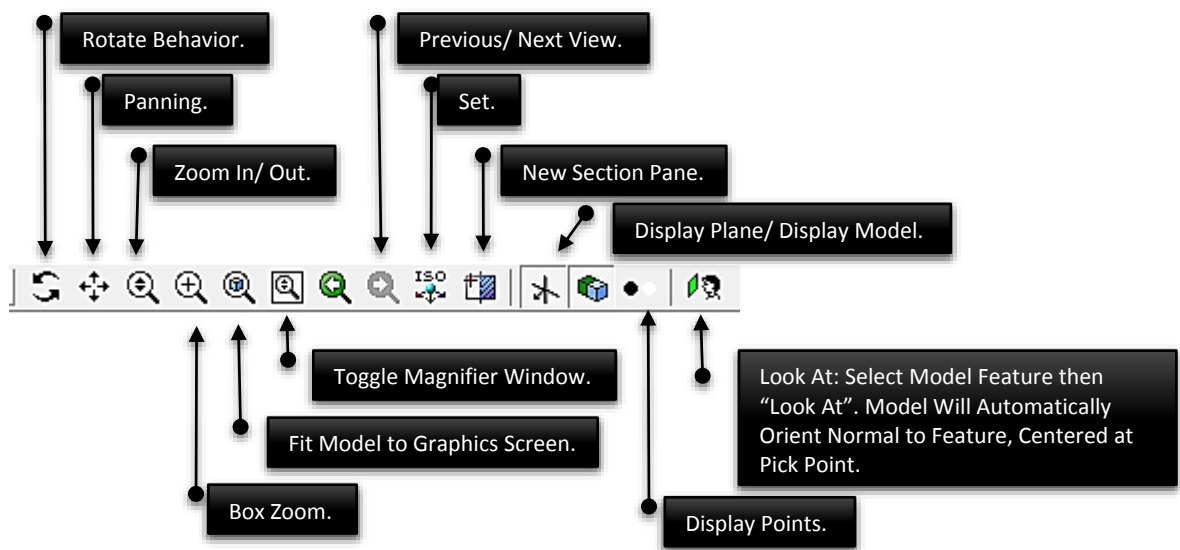

Additional Mouse Controls

- # While in Select Mode:
  - o Center Mouse Button → Free Rotations.
  - o Right Mouse Button → Box Zoom.
  - o Shift+ Center Mouse Button → Zoom.
- # While in Rotate, Pan or Zoom Mode:
  - o Left click on model temporarily resets center of view and rotation at cursor location.
  - o Left click in open area re-centers model and rotation center to centroid.
- # Mouse Cursor is Context Sensitive.
  - o Indication Current Mouse Actions [Viewing, Rotation, Selecting, Sketch AutoConstrains, etc.]

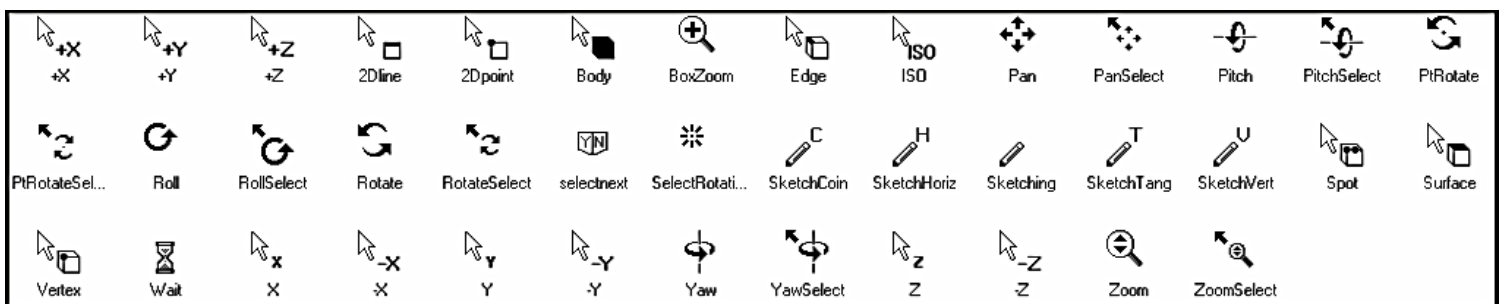

## Understanding Cell States

ANSYS Workbench integrates multiple applications into a single seamless project flow, where individual cells can obtain data from and provide data to other cells. As a result of this flow of data, a cell's state can change in response to changes made up to the project. ANSYS Workbench provides visual indications of a cell's state at any given time via icons on the right side of each cell.

Cell states can be divided into the following categories:

[Reference](#) --> [ANSYS Help v.17.0.](#)

### i. Typical Cell States

#### ➤ Unfulfilled

Required upstream data does not exist. Some applications may not allow you to open them with the cell in this state. For example, if you have not yet assigned a geometry to a system, all downstream cells will appear as unfulfilled, because they cannot progress until you assign a geometry.

#### ➤ Refresh Required

Upstream data has changed since the last refresh or update. You may or may not need to regenerate output data. When a cell is in a Refresh Required state, you can Edit the cell, Refresh the data, Update Upstream Components, or Update the cell. The advantage to simply refreshing a cell rather than performing a full update is that you can be alerted to potential effects on downstream cells before updating and can make any necessary adjustments. This option is especially useful if you have a complex system in which an update could take significant time and/or computer resources.

#### ➤ Attention Required

All of the cell's inputs are current; however, you must take a corrective action to proceed. To complete the corrective action, you may need to interact with this cell or with an upstream cell that provides data to this cell. Cells in this state cannot be updated until the corrective action is taken.

This state can also signify that no upstream data is available, but you can still interact with the cell. For instance, some applications support an "empty" mode of operation, in which it is possible to enter the application and perform operations regardless of the consumption of upstream data.

#### ➤ Update Required

Local data has changed and the output of the cell needs to be regenerated.

#### ➤ Up to Date

An Update has been performed on the cell and no failures have occurred. It is possible to edit the cell and for the cell to provide up-to-date generated data to other cells.

#### ➤ Input Changes Pending

The cell is locally up-to-date but may change when next updated as a result of changes made to upstream cells.

### ii. Solution-Specific States

#### ➤ Interrupted, Update Required

Indicates that you have interrupted the solution during an update, leaving the cell paused in an Update Required state. This option performs a graceful stop of the solver, which will complete its current iteration; although some calculations may have been performed, output parameters will not be updated. A solution file will be written containing any results that have been calculated. The solve will be resumed with the next update command.

➤ **Interrupted, Up to Date** 

Indicates that you have interrupted the solution during an update, leaving the cell in an Up-to-Date state.

This option performs a graceful stop of the solver, which will complete its current iteration; output parameters will be updated according to the calculations performed thus far and a solution file will be written. You can use the solution for post processing (to look at the intermediate result, for example). Because the cell is already up-to-date, it will not be affected by a design point update; to resume the solve, right-click and select the **Continue Calculation** option.

➤ **Pending** 

Signifies that a batch or asynchronous solution is in progress. When a cell enters the Pending state, you can interact with the project to exit ANSYS Workbench or work with other parts of the project. If you make changes to the project that are upstream of the updating cell, then the cell will not be in an up-to-date state when the solution completes.

iii. *Failure States*

➤ **Refresh Failed, Refresh Required** 

The last attempt to refresh cell input data failed and the cell remains in a refresh required state.

➤ **Update Failed, Update Required** 

The last attempt to update the cell and calculate output data failed and the cell remains in an update required state.

➤ **Update Failed, Attention Required** 

The last attempt to update the cell and calculate output data failed. The cell remains in an attention required state.

If an action results in a failure state, you can view any related error messages in the **Messages** view by clicking the **Show Messages** button on the lower right portion of the ANSYS Workbench tab.

## 3D Geometry

Reference --> Autodesk Network Article.

### Bodies and Parts

# DesignModeler is primarily intended to provide geometry to an analysis environment. For this reason we need to see how DesignModeler treats various geometries.

# DesignModeler contains three different body types:

- Solid Body: A body with surface area and volume.
- Surface Body: A body with surface area but no volume.
- Line Body: A body which consists entirely of edges, no area, and no volume.

# By default, DesignModeler places each body into one part by itself.

# There are two body types in DesignModeler:

Active:

- Body can be modified by normal modeling operations.
- Active bodies are displayed in blue in the Feature Tree View.
- The body's icon in the Feature Tree View is dependent on its type – solid, surface, or line.

○ Frozen:

- Two Purposes:
  - Provides alternate method for Sim Assembly Modeling.
  - Provides ability to “Slice” parts.
- A Frozen body is immune to all modeling operations except slicing.
- To move all Active bodies to the Frozen state, use the Freeze feature.
- To move individual bodies from the Frozen to Active, select the body and use the Unfreeze feature.

○ Frozen bodies are displayed “lighter” in the Tree View.

# Body Suppression:

- Suppressed bodies are not plotted.
- Suppressed bodies are not sent to Design Simulation for analysis, nor are they included in the model when exporting to a Parasolid (.x\_t) or ANSYS Neutral File (.anf) format.
- In the Tree View an “X” is shown near suppressed bodies.

Unsuppressed

Suppressed

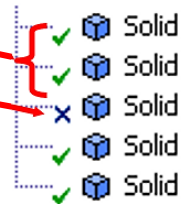

# Parts:

- By default, the DesignModeler places each body into one part by itself.
- You can group bodies into parts.
  - These parts will be transferred to Design Simulation as parts consisting of multiple bodies (volumes), but **Shared Topology**.
- To form a new part, select two or more bodies from the graphics screen and use → Tools → Form New Part.
- The Form New Part option is available only when bodies are selected and you are not in a feature creation or feature edit state.

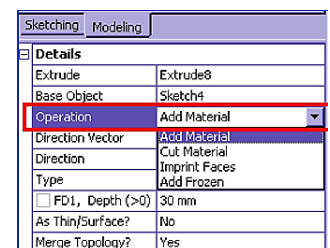
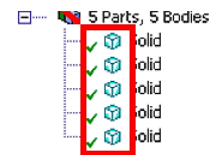
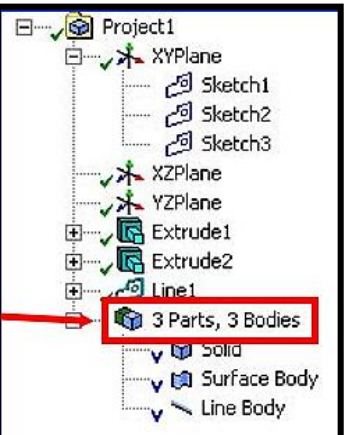

### Boolean Operations

# You can apply five different Boolean operations to 3D features:

- Add Material: Creates material and merges it with the active bodies.
- Cut Material: Removes material from active bodies.
- Slice Material: Slices frozen bodies into pieces. [Available only when all bodies in the model are frozen]
- Imprint Faces: Similar to Slice, except that only the faces of the bodies are split, and edges are imprinted if necessary.
- Add Frozen: Similar to Add Material, except that the feature bodies are not merged with the existing model but rather added as frozen bodies.

## Feature Type

Details of Extrude2	
Extrude	
Geometry	
Operation	Add Material
Direction Vector	None (Normal)
Direction	
Extent Type	To Faces
	Fixed
	Through All
	To Next
	To Faces
	To Surface

- # Fixed:
  - Fixed extents will extrude the profiles the exact distance specified by the depth property. The feature preview shows an exact representation of how the feature will be created.
- # Through All Type:
  - Will extend the profile through the entire model.
  - When adding material the extended profile must fully intersect the model.
- # To Next:
  - Add will extend the profile up to the first surface it encounters.
  - Cut, Imprint and Slice will extend the profile up to and through the first surface or volume it encounters.
- # To Faces:
  - Allows you to extend the Extrude feature up to a boundary formed by one or more faces.
  - For multiple profiles make sure that each profile has at least one face intersecting its extent. Otherwise, an extent error will result.
  - The “To Faces” option is different from “To Next”. To Next does not mean “to the next face”, but rather “through the next chunk of the body”.
  - The “To Faces” option can be used with respect to faces of frozen bodies.
- # To Surface:
  - Option is similar to “To Faces”, except only one face can be selected. The extent is defined by the underlying and possibly unbounded surface of the selected face.

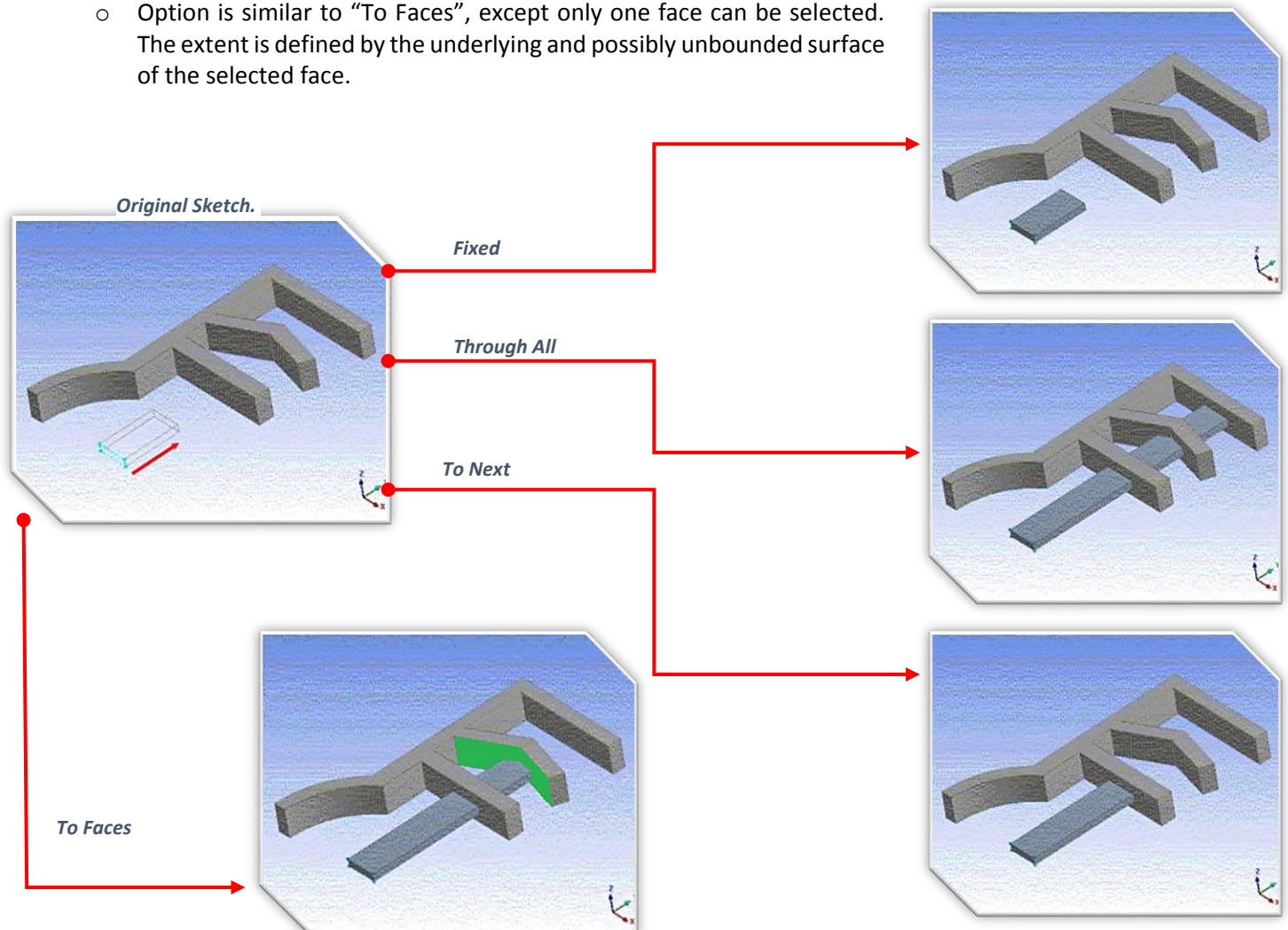

## Feature Creation

## # Extrusions:

- Extrusions include solids, surfaces and thin walled features.
- To create surfaces, select “as thin/surface” and set the inner and outer thickness to zero.
- The active sketch is the default input but can be changed by selecting the desired sketch in the Tree View.
- The Detail View is used to set the Extrude depth, direction and Boolean Operation (Add, Cut, Slice, Imprint or Add Frozen).
- The Generate button completes the feature creation.

Sketching Modeling	
Details of Extrude1	
Extrude	Extrude1
Base Object	Sketch1
Operation	Add Material
Direction Vector	None (Normal)
Direction	Normal
Type	Fixed
<input type="checkbox"/> FD1, Depth (>0)	30 mm
As Thin/Surface?	Yes
<input type="checkbox"/> FD2, Inward Thickness (>=0)	0 mm
<input type="checkbox"/> FD3, Outward Thickness (>=0)	0 mm
Merge Topology?	Yes

## # Revolve:

- Active sketch is rotated to create 3D Geometry.
- Select axis of rotation from details.
- Direction Property for Revolve:
  - Normal: Revolves in positive Z direction of base object.
  - Reversed: Revolves in negative Z direction of base object.
  - Both- Symmetric: Applies feature similar in both directions.
  - Both- Asymmetric: Applies feature in both directions unevenly.
- The Generate button completes the feature creation.

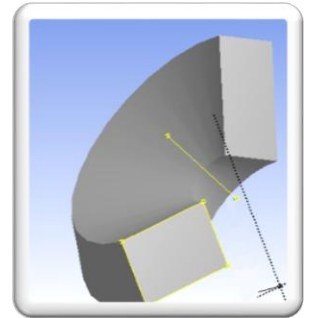

## # Sweep:

- Solids, Surfaces and thin walled features can be created by using this feature to sweep a profile along a path.
- Scale and Turns properties can be used to create helical sweeps.
  - Scale: Tapers or expands the profile along the path of the sweep.
  - Turns: Twists the profile as sweeps along the path.
  - A negative value for Turns will make the profile rotate about the path in the opposite direction.
- Alignment:
  - Path Tangent: Reorients the profile as it is swept along the path to keep the profile in the path's tangent direction.
  - Global: The profile's orientation remains constant as it is swept along the path, regardless of the path's shape.

## # Skin/ Loft:

- Takes a series of profiles from different planes to create 3D Geometry fitting through them.
  - A profile is a sketch with one closed or open loop or a plane from a face.
  - All profiles must have the same number of edges.
  - Open and closed profiles cannot be mixed.
  - All profiles must be of the same type.
- Sketches and planes can be selected by clicking on their edges or points in the graphics area, or by clicking on the sketch or plane in the feature tree.
- After selecting an adequate number of profiles, a preview will appear showing the selected profiles and the guide polygon.
- The guide polygon is a gray poly-line which shows how the vertices between the profiles will line up with each other.
- Skin/ Loft operation relies heavily on Right Mouse Button menu choices.

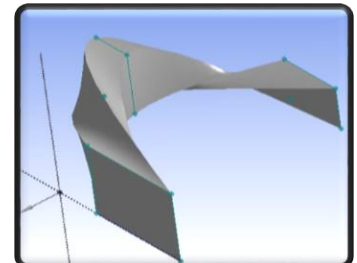
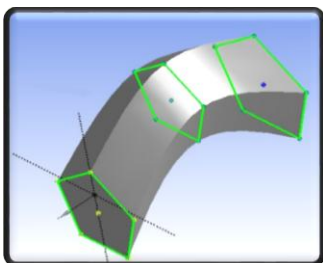

## # Point:

- The Point feature allows for controlled and fully dimensioned placement of points relative to selected model faces and edges.
- Select a set of base faces and guide edges.
- Select the Point (analysis) Type:
  - Spot Weld: Used for “welding” together otherwise disjointed parts in an assembly.
  - Point Load: Used for “hard points” (nodal points) in the analysis.
  - Construction Point: No points of this type are passed to simulation.
- Select from three possible Point Definition options each with certain placement definitions:
  - Single --> Sigma and Offset.
  - Sequence By Delta --> Sigma, Offset, Delta.
  - Sequence By N --> Sigma, Offset, N, Omega.
  - From Coordinates File --> Formatted text file, similar to 3D curve.
- Sigma: The distance between the beginning of the chain of guide edges and the placement of the first point.
- Edge Offset: The distance between the guide edges and the placement of the spots on the set of base faces.
- Delta: The distance, measured on the guide edges, between two consecutive points, for the Sequence By Delta option.
- N: The number of points to be placed, relative to the chain of guide edges, in case of the Sequence By N option.
- Omega: The distance between the end of the chain of guide edges and the placement of the last spot, for the Sequence By N option.

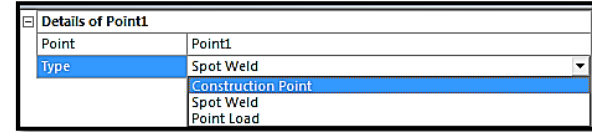

## # Examples:

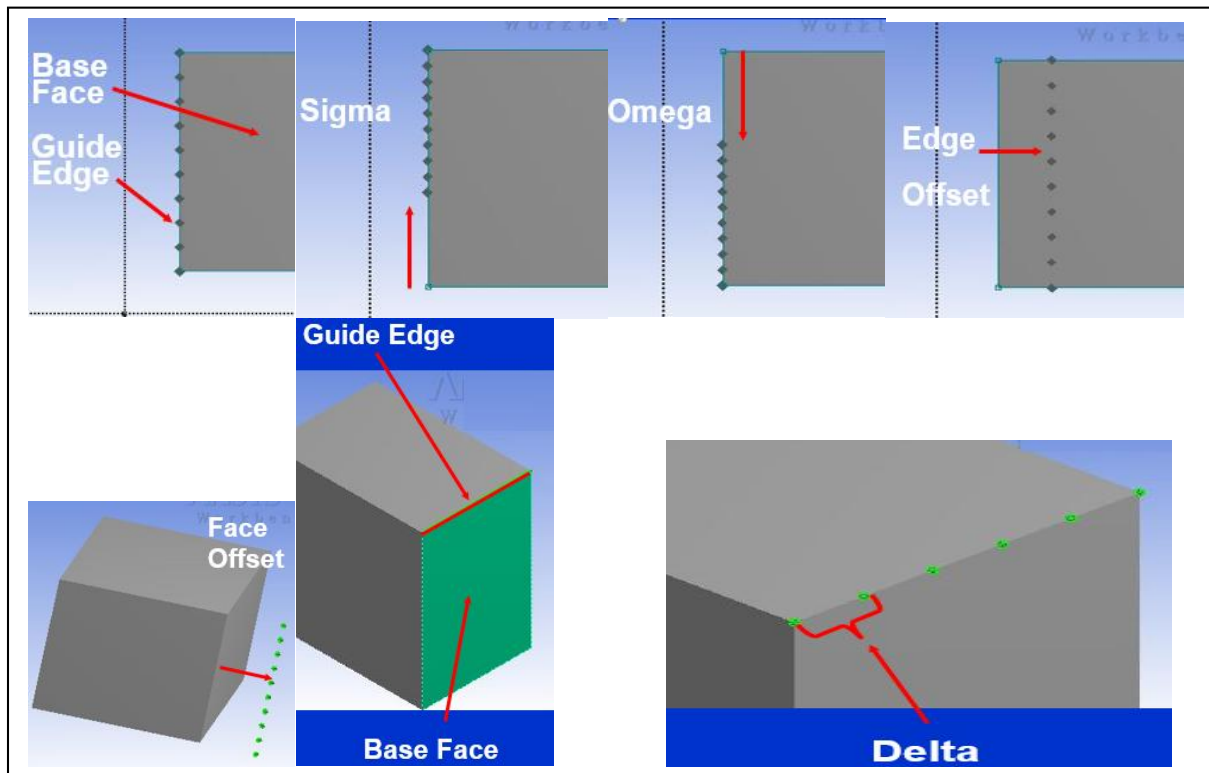
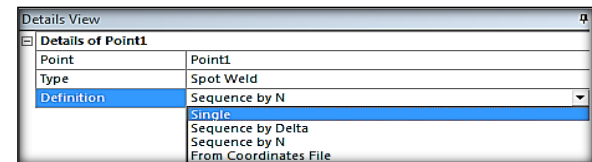

## CHAPTER\_I: CHILD SWING

## 1.1 Problem Description

The purpose of this chapter is to find out the deformation of the beam and the displacement of its end point. Furthermore we will examine, how the stress will look like, when a loading by some specific weight, defined by the force.

# Inputs →

### Dimensions

$l = 1000 \text{ mm};$        $t = 4 \text{ mm};$        $a = 50 \text{ mm};$   
 $D = 30 \text{ mm};$        $b = 30 \text{ mm};$        $F = 200 \text{ N};$

### Material

Structural Steel: Young's Modulus = 200 GPa;  
 Poisson's Ratio = 0.3;

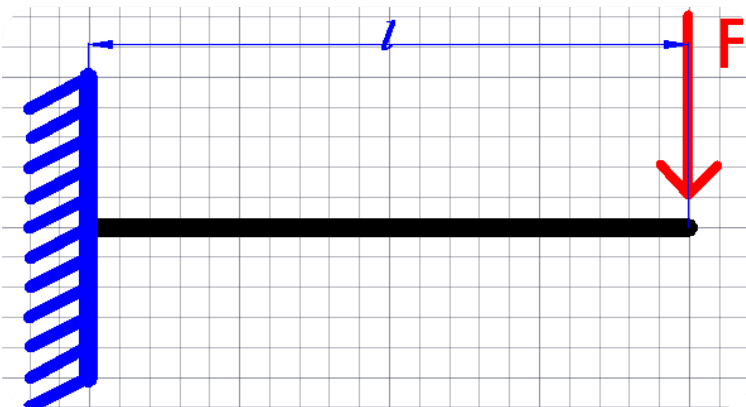

Circle and Channel Cross-Section

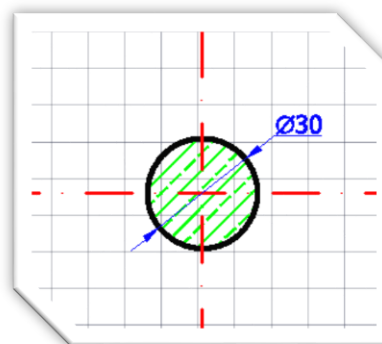
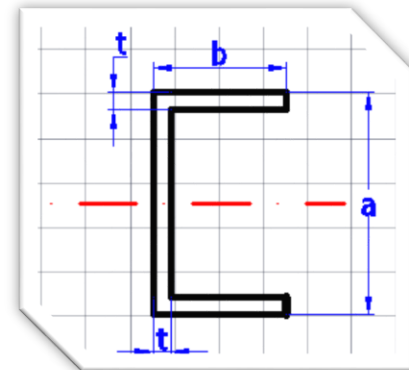

## 1.2 Workbench GUI

Reference → *Finite Element Simulations with ANSYS Workbench 13* by Huei- Huang Lee.

You can launch Workbench by selecting it from the Start Menu. [1] The contents of the Start Menu in your computer may be different from what you see here, depending on your installation (licensing). “Workbench GUI” (graphic user interface) will show up. [2] “Workbench GUI” is a gateway to workbench application i.e., all the workbench application can be accessed via “Workbench GUI”. There are two types of ANSYS applications: Native and Data integrated applications.

Native applications are directly supported in “Workbench GUI”, their program codes and database bind together. Native applications which will be used to this book are: “*Project Schematic*”, “*Engineering Data*”, and “*Design Exploration*”.

Data Integrated applications are independent programs. They have their own GUI’s and databases. They communicate with “Workbench GUI” or other program applications through out-of-core database files. Data integrated applications which will be used in this book are: “*Design Modeler*”, “*Mechanical*”.

① Workbench GUI.

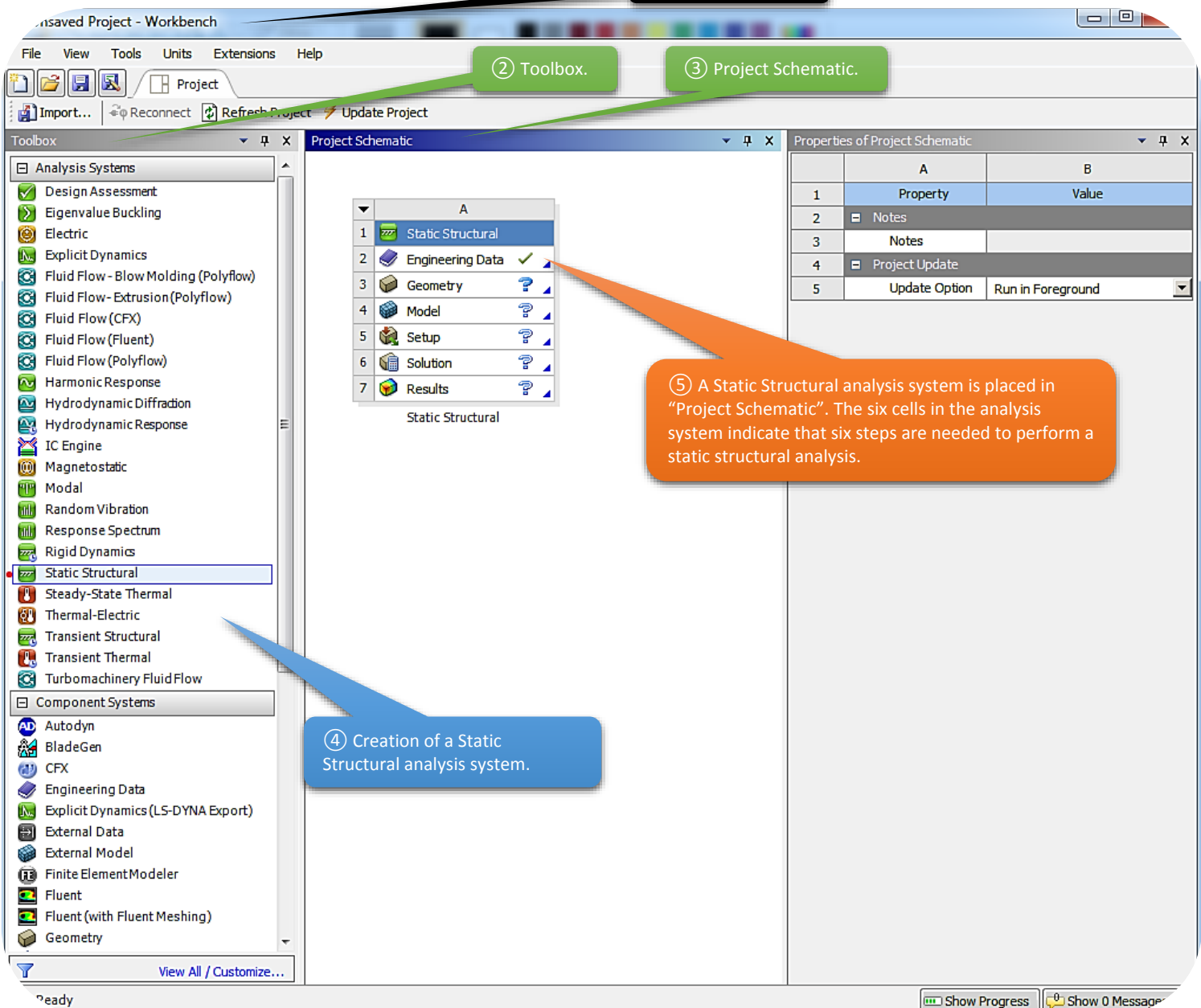

### 1.3 Preparing Engineering Data

Double clicking to “Engineering Data” cell, will start Engineering Data application, where we want to specify our material properties. In this task our material is made by steel [Young’s Modulus= 200GPa, Poisson’s Ratio= 0,3] and as we can see, we don’t have to make any changes, as the default material properties of structural steel match with our requirements.

① Engineering Data application shows up on Workbench GUI.

④ Close Engineering Data and return to the Project Schematic.

② Structural steel material is selected.

③ Change material properties if they are not the same.

	A	B
1	Temperature (C)	Poisson's Ratio
2		0,3
*		

	A	B	C	D	E
1	Propriety	Value	Unit		
2	Density	7850	kg m <sup>-3</sup>		
3	Isotropic Thermal Expansion Coefficient of Thermal Expansion				
6	Isotropic Elasticity				
7	Derive from	Young's...			
8	Young's Modulus	2E+05	MPa		
9	Poisson's Ratio	0,3			
10	Bulk Modulus	1,6667E+11	Pa		
11	Shear Modulus	7,6923E+10	Pa		
12	Field Variables				
13	Temperature	Yes			
14	Shear Angle	No			

Temperature [C]	Poisson's Ratio
0	0.3

## 1.4 Create Geometric Model

Double clicking “Geometry” cell will open up “Design Modeler” application. The functions of Design Modeler are similar to any other C.A.D. (Computer Aided Design) software such as *Solidworks*, *Creo Elements/ Pro Engineer*, except that Design Modeler is specifically designed to create geometric models for use in ANSYS Workbench simulations.

### 1.4.1 2D and 3D Simulations

**Reference** → *Finite Element Simulations with ANSYS Workbench 13* by Huei- Huang Lee.

Workbench supports 2D and 3D simulations. For 3D simulations Workbench supports three types of geometric bodies: [1] Solid Bodies (which have volume) [2] Surface Bodies (which do not have volume but have surface areas) [3] Line Bodies (which do not have volume or surface areas but have length). Thin shell structures are often modeled as surface bodies. Beam or frame structures are often modeled as line bodies. A 2D model must be created entirely on <XYPlane>.

### 1.4.2 More on Geometric Modeling

Creating a geometric model is sometimes complicated and not as trivial as that in our first task. However it often can be viewed as a series of two-step operations as demonstrated in this case: Drawing a sketch and then using the sketch to create a 3D body by one of the techniques provided by Design Modeler such as *extrusion*, *revolution*, *sweeping*, *skinlofting*, etc.

Geometric modeling is the first step towards the success of simulations. For an engineer to be successful in simulation he/she must be proficient enough in geometric modeling.

- Time to focus on our task and get more specific in certain commands of the Design Modeler application.

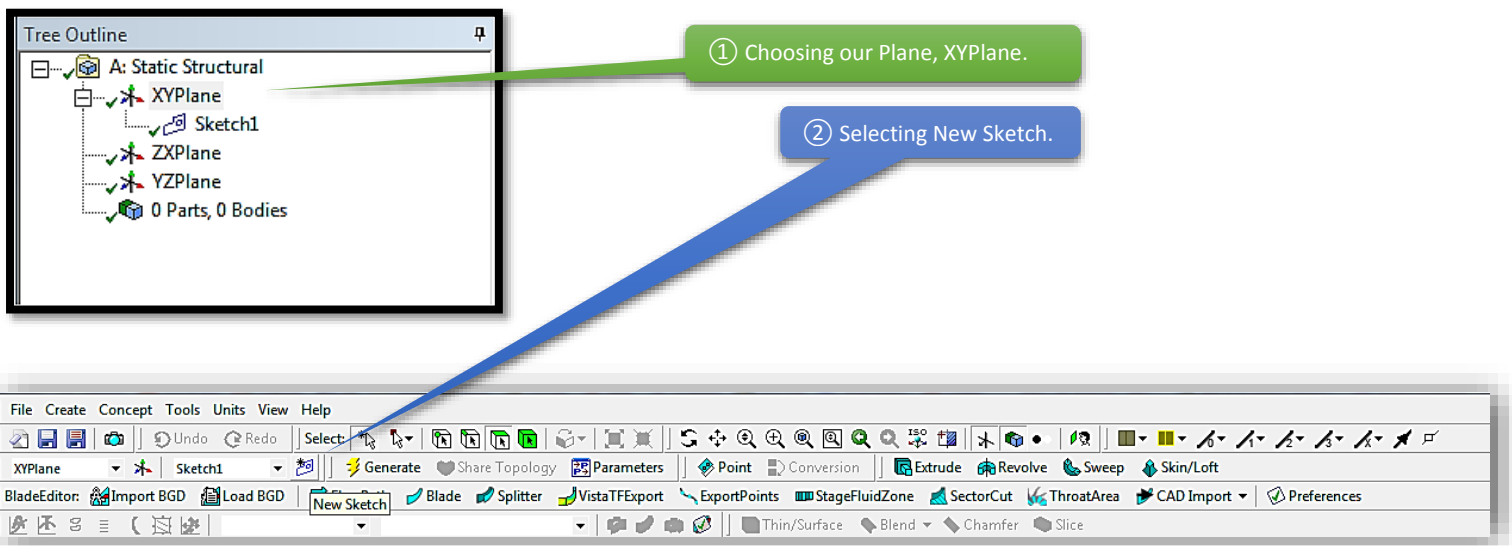

- Now you can create a line with the given dimensions in the newly created “Sketch 1”.

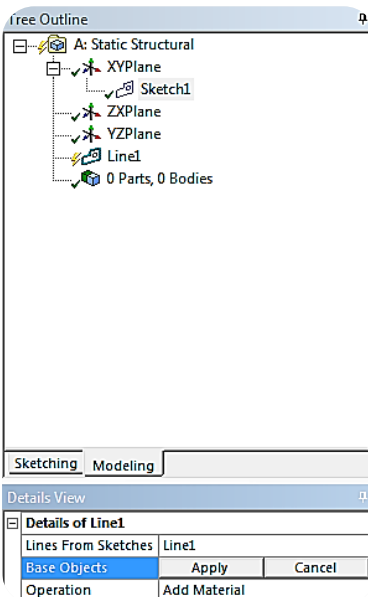
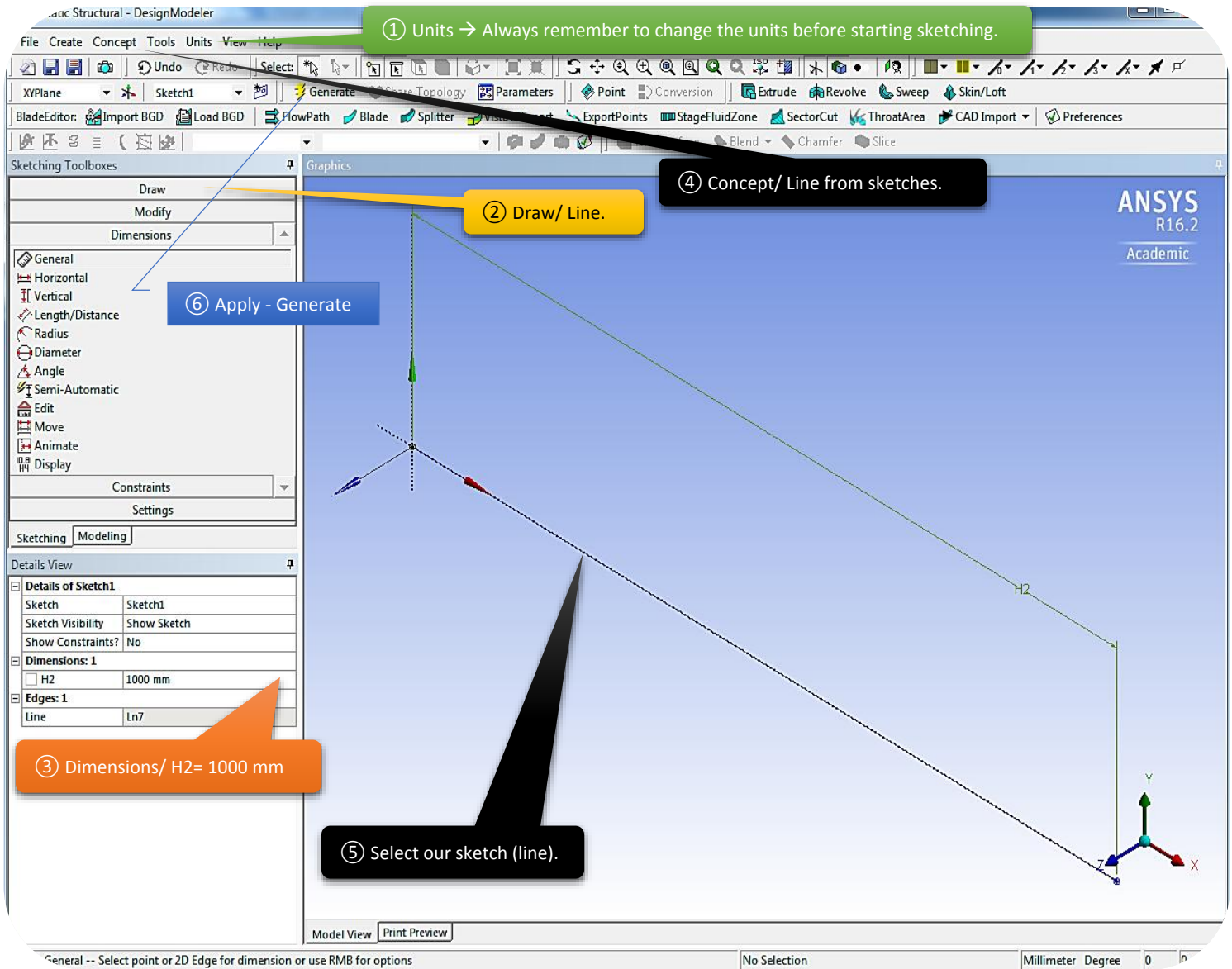

**7** Concept/ Cross Section/ Circular.

**8** Select the geometry, in our case the line.

**9** Change to the dimensions that we are interested in.

**10** Select Line Body, and change the Cross Section to Circular1.

**11** Pull down "View" tab, and select "Cross Section Solids", to be able to see our cross section.

**Details View 1 (Left):**

Details of Line Body	
Body	Line Body
Faces	0
Edges	1
Vertices	2
Cross Section	Not selected
Shared Topology Method	Edge Joints
Geometry Type	DesignModeler

**Details View 2 (Right):**

Details of Circular1	
Sketch	Circular1
Show Constraints?	No
<b>Dimensions: 1</b>	
<input type="checkbox"/> R	15 mm
<b>Edges: 1</b>	
Full Circle	Cr10

- After sketching our geometry we need to create a "Line Body". Also we are going to need 2 different kind of Cross\_Section. The way to do that is described in the pictures above.

*Reference --> Finite Element Simulations with ANSYS Workbench 13 by Huei- Huang Lee.*

### 1.5 Divide Geometric Model Into Finite Elements

The procedure that Workbench solves a problem can be viewed as two major steps: ① Establishing a set of equations that govern the behavior of the problem and ② Solving the equations. The problem domain (i.e. the geometric model) is usually so complicated that it is almost impossible to establish and solve the governing equations directly. A core idea in the finite element method is to divide the entire problem domain into many smaller and simpler domains called "the finite elements". The elements are connected by nodes. The governing equations for all elements will be solved simultaneously.

The dividing of geometric model into elements is called *meshing* and the collection of the elements is called *the finite element mesh* or sometimes called *the finite element model*. Strictly speaking, a finite element model should mean a finite element mesh PLUS it's environment conditions.

- Double clicking "Model" cell in the analysis template will bring up "Mechanical GUI".

The rest of the simulation will take place also in "Mechanical GUI".  
 Meshing --> Setup Loads/Supports --> Solution --> View the results.

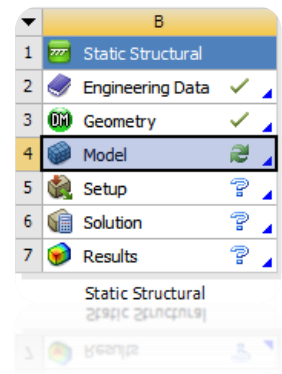

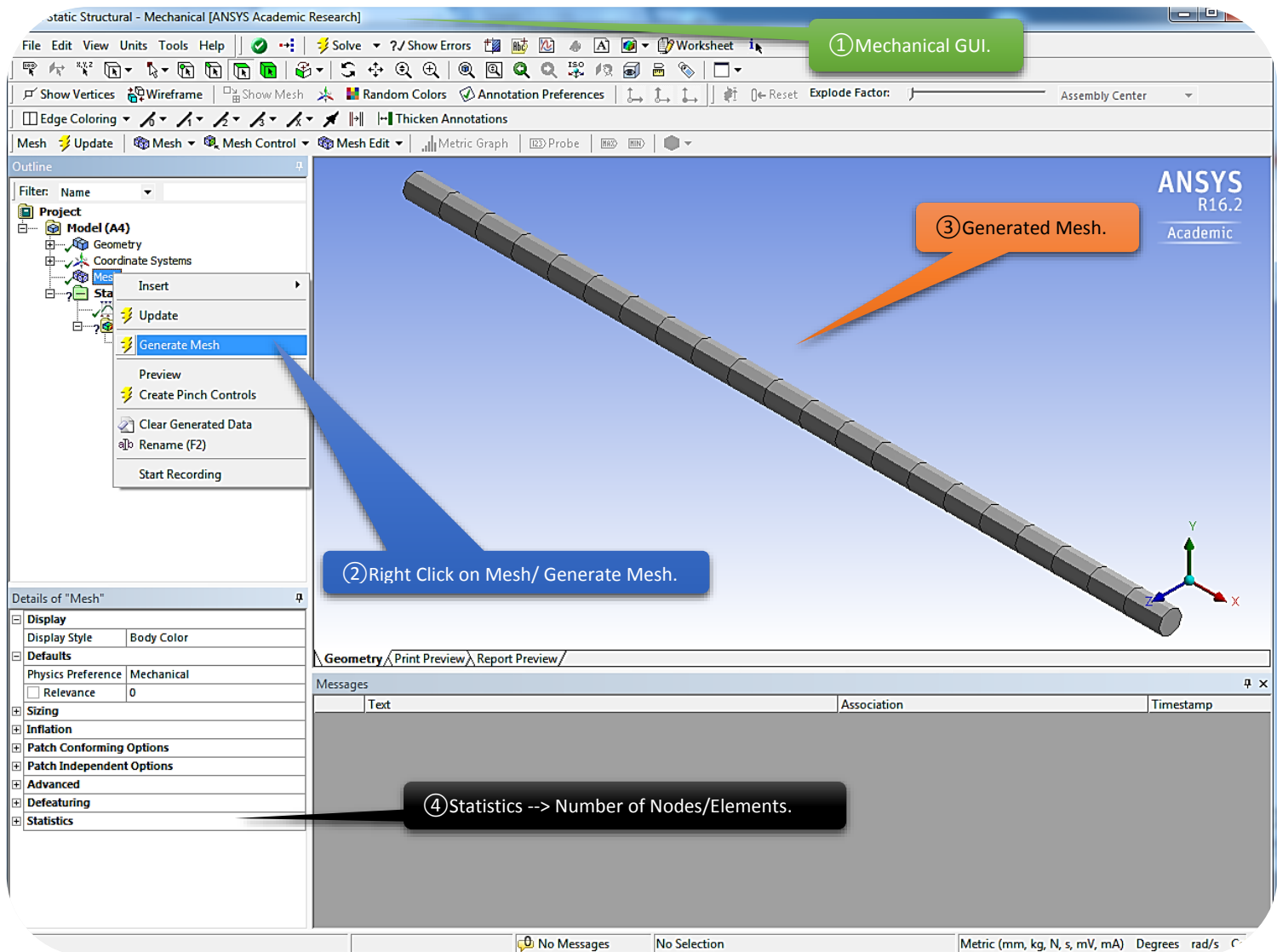

- Quality of meshing cannot be overemphasized. Although it is possible to let ANSYS Workbench perform the meshing automatically, its quality is not guaranteed.

## 1.6 Set Up Loads and Supports

**Reference** --> *Finite Element Simulations with ANSYS Workbench 13* by Huei- Huang Lee.

In the real world, all things are part of the world and they interact with each other. When we take an object apart for simulation, we are cutting it away from the rest of the world. The cutting surfaces of the model is called the boundary of the model. Where we cut the boundary is arbitrary – as long as we can specify the boundary conditions on all of the boundary surfaces. In Workbench all conditions affecting the response of the model are called the environment conditions which include boundary conditions. Strictly speaking, environment conditions include conditions that are not specified on the boundaries, for example, temperature changes over the entire body (not just on the boundary). In Workbench we don't use the term "boundary conditions", instead we will use the term "environment conditions", which includes boundary and non-boundary conditions.

- In our case scenario, the things surrounding our geometry are:
  - i. Atmosphere air around all the rest of boundary surfaces. BUT assuming the atmosphere air has very little interaction with the model we simply neglect it. We model all other boundary surfaces as free boundaries.
  - ii. Fixed support in one end.
  - iii. Force on the other end equal to 500N.

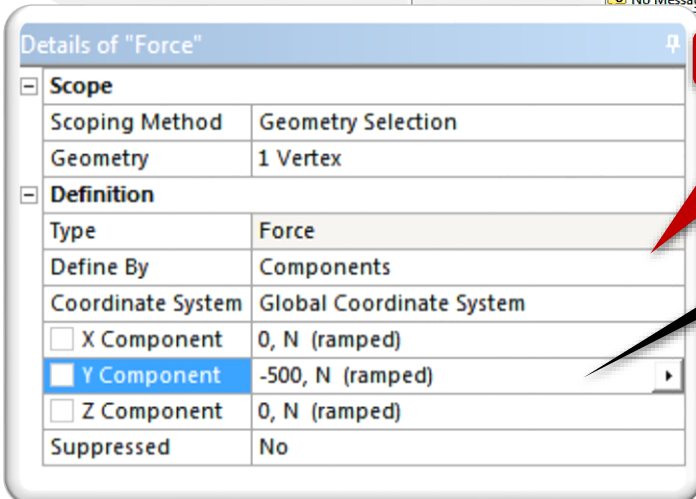
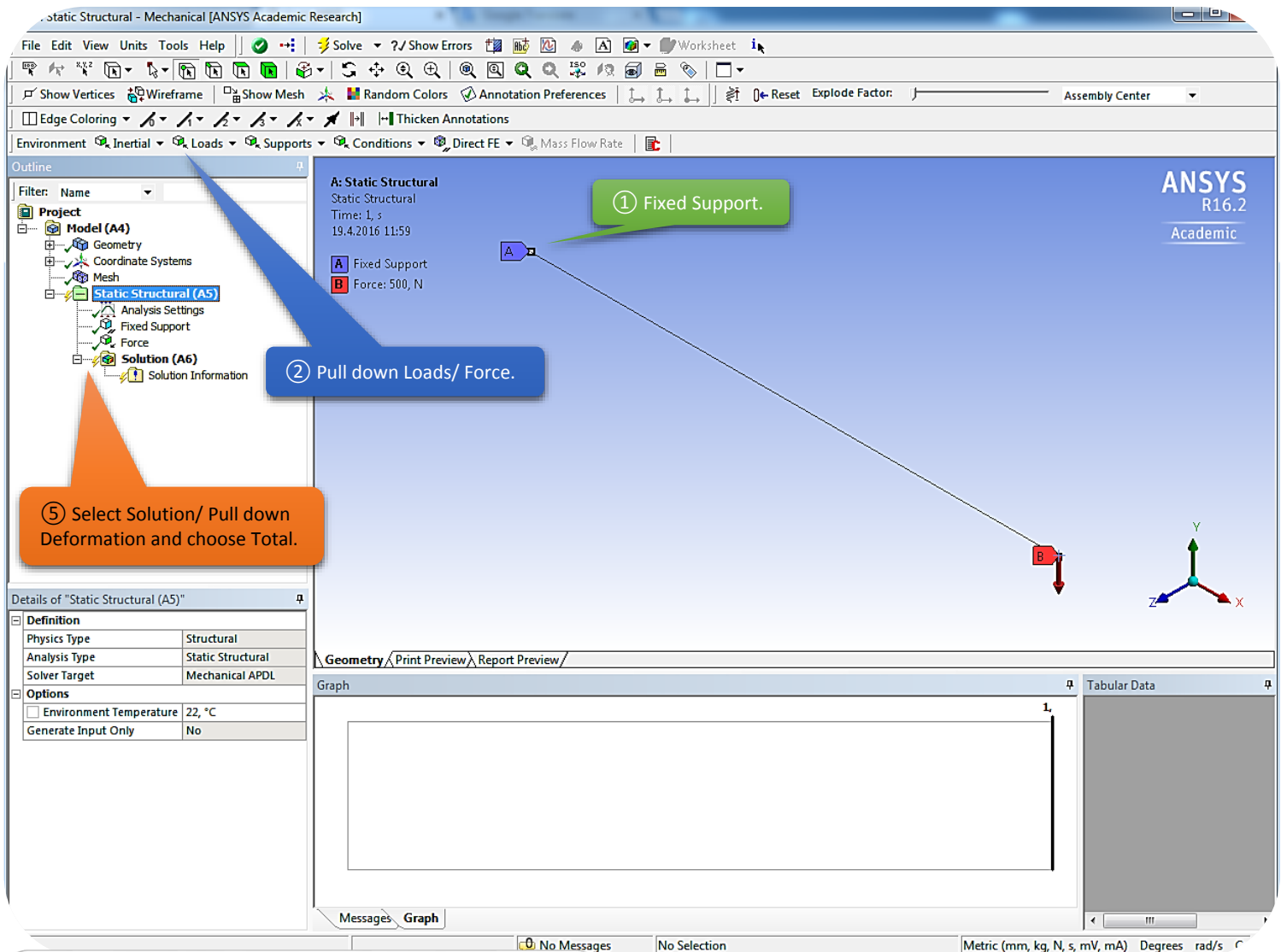

③ Switch Define By to Components.

④ Y Component -500N.

*In this task we are only interested in Deformation, otherwise we could choose from the Strain/ Stress/ Energy tabs for more solution options. We will introduce you those options in further tasks.*

## 1.7 Solve the Finite Element Model

To solve a finite element model, simply click <Solve> in Mechanical GUI. The solution procedure is entirely automatic. The time to complete a simulation depends on the problem size and complexity. After the solution, the numerical results are stored in a database.

## 1.8 Viewing the Results

After the solution, numerical results are stored in databases, they can be viewed upon your request. In our case we are most concerned about the vertical deflection. The deformation also can be animated in the GUI. Note that the deflection is measured at the tip.

ANSYS R16.2 Academic

① To solve the F.E. Model simply click on Solve.

② The deformed shape.

③ Min. and Max. deformation results.

④ Animating deformation.

Details of "Total Deformation"

Scope	
Scoping Method	Geometry Selection
Geometry	All Bodies
Definition	
Type	Total Deformation
By	Time
<input type="checkbox"/> Display Time	Last
Calculate Time History	Yes
Identifier	
Suppressed	No
Results	
<input type="checkbox"/> Minimum	0, mm
<input type="checkbox"/> Maximum	21,013 mm
Information	

Graph

Animation ▶ 10 Frames 2 Sec (Auto) 3 Cycles

Tabular Data

Time [s]	Minimum [mm]
1	0

### 1.9 Second Part of Our Task

In order to change the type of our cross section, we have to go back to Design Modeler and add one more type of cross section.

Note: We don't have to close Mechanical GUI, just Alt+Tab back to Geometry Mode.

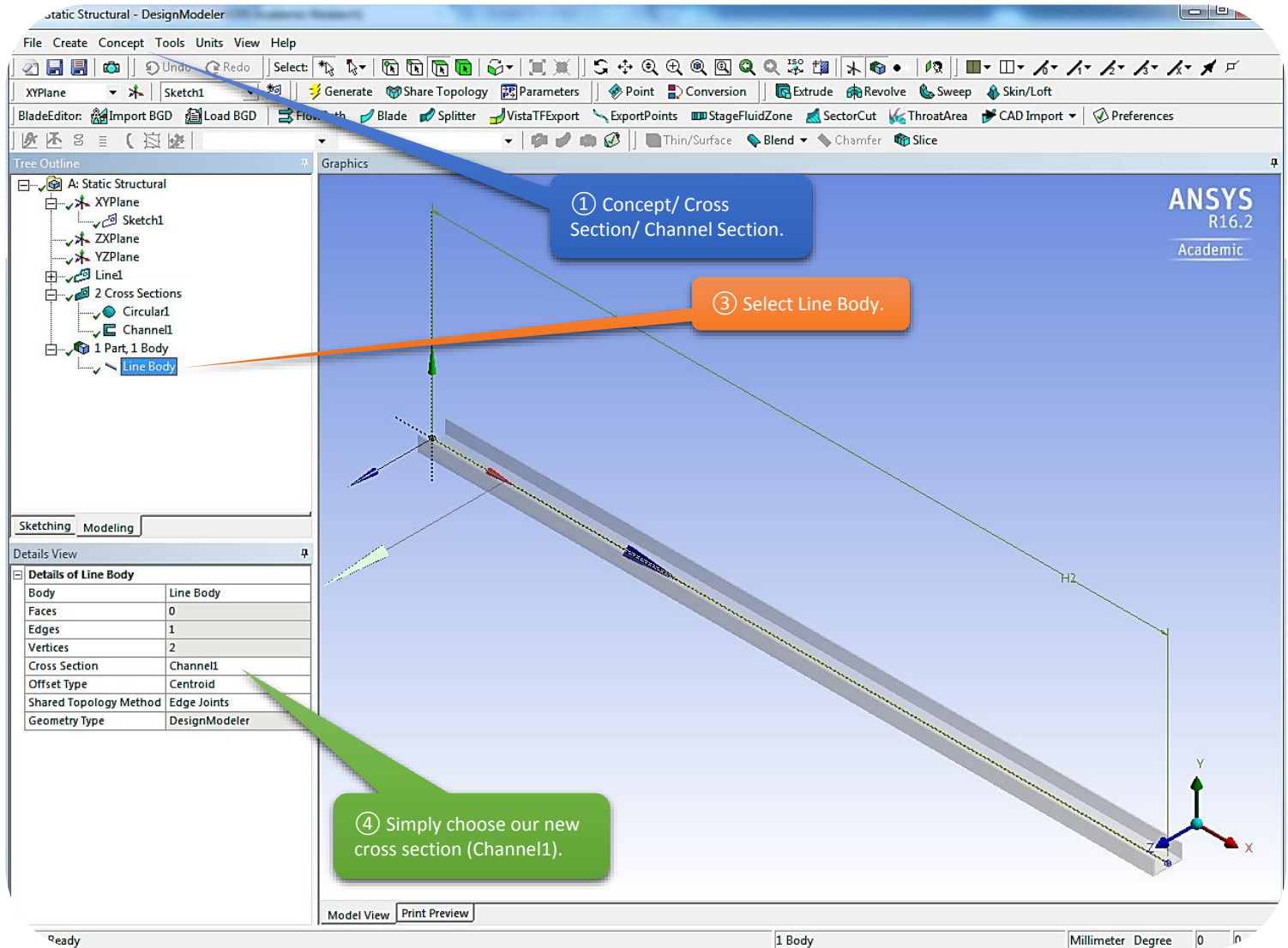

Details of Channel1	
Sketch	Channel1
Show Constraints?	No
<b>Dimensions: 6</b>	
<input type="checkbox"/> W1	20 mm
<input type="checkbox"/> W2	20 mm
<input type="checkbox"/> W3	40 mm
<input type="checkbox"/> t1	2 mm
<input type="checkbox"/> t2	2 mm
<input type="checkbox"/> t3	2 mm

- After you are finished adding the new cross section to our model, hit Alt+Tab again to get you back to “Mechanical GUI”. Now all we have to do is update the geometry (since we still got the geometry with the previous cross section shown to the Mechanical) and solve the problem again.

The screenshot displays the ANSYS Mechanical GUI for a static structural analysis of a beam. The interface includes a menu bar, a toolbar, and several panels. The main view shows a 3D model of a beam with a color-coded deformation plot. A legend on the left indicates a maximum deformation of 144.8 mm. The software version is ANSYS R16.2 Academic.

Four numbered callouts provide instructions for the workflow:

- ① Right click Geometry/ Update Geometry from Source.
- ② Right click Mesh/ Generate Mesh.
- ③ Solve
- ④ Select Solution to see the results.

The "Details of 'Total Deformation'" panel is visible, showing the following information:

Scope	
Scoping Method	Geometry Selection
Geometry	All Bodies
Definition	
Type	Total Deformation
By	Time
<input type="checkbox"/> Display Time	Last
Calculate Time History	Yes
Identifier	
Suppressed	No
Results	
<input type="checkbox"/> Minimum	0, mm
<input type="checkbox"/> Maximum	144,8 mm
Information	

The Messages panel shows a warning: "The deformation is large compared to the model bounding box. Verify boundary cond". The Tabular Data panel shows the following data:

Time [s]	Minimum [mm]
1	0

- There is a lot different things that we can do to change the geometry and see results of different aspects. Let's try and change the cross section's alignment. Go back to Design Modeler and change the alignment according to the picture.

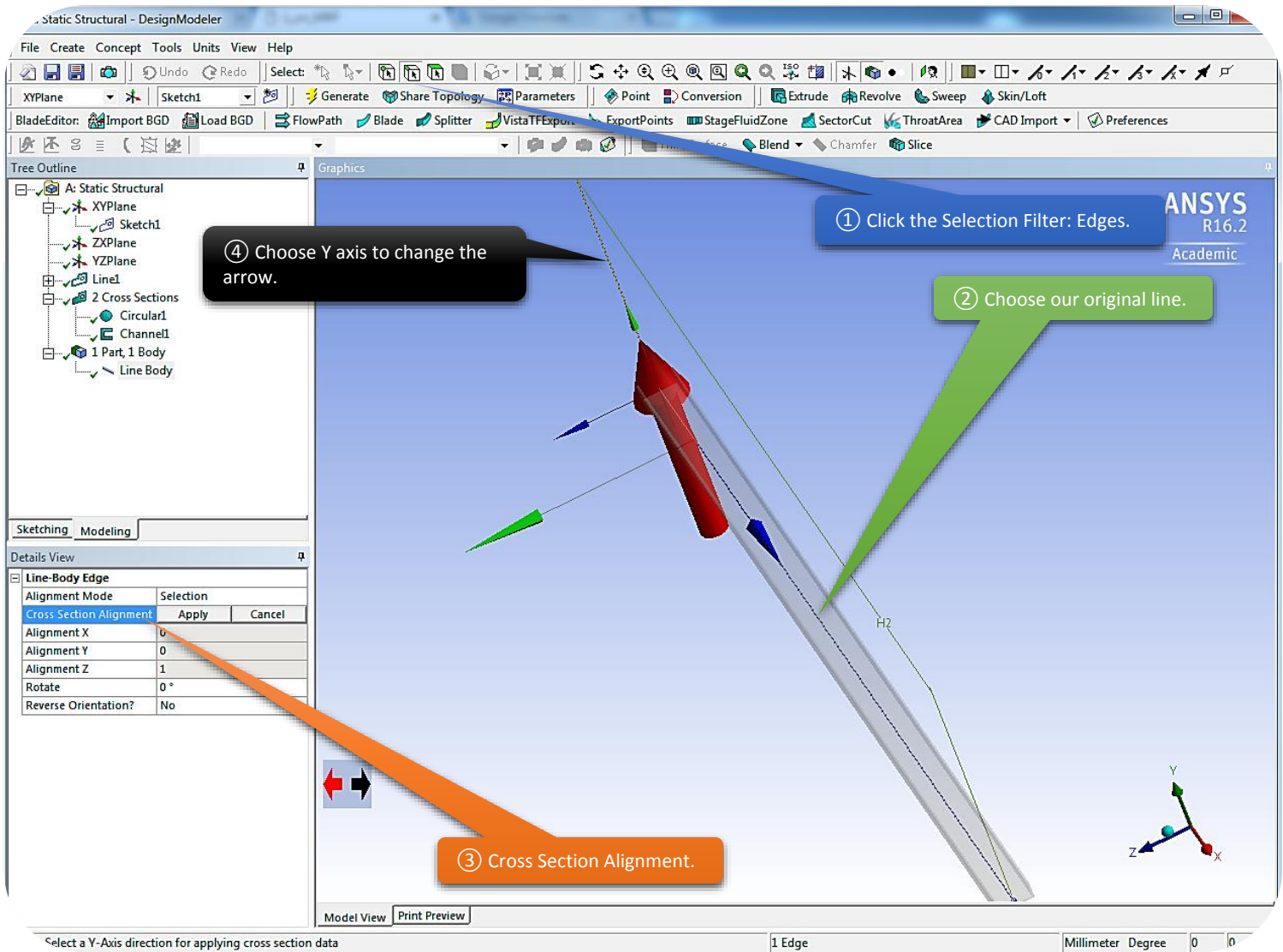

- After finishing the configurations in Design Modeler, Alt+Tab again to get back to Mechanical GUI, update geometry from source again, mesh the model and solve it.

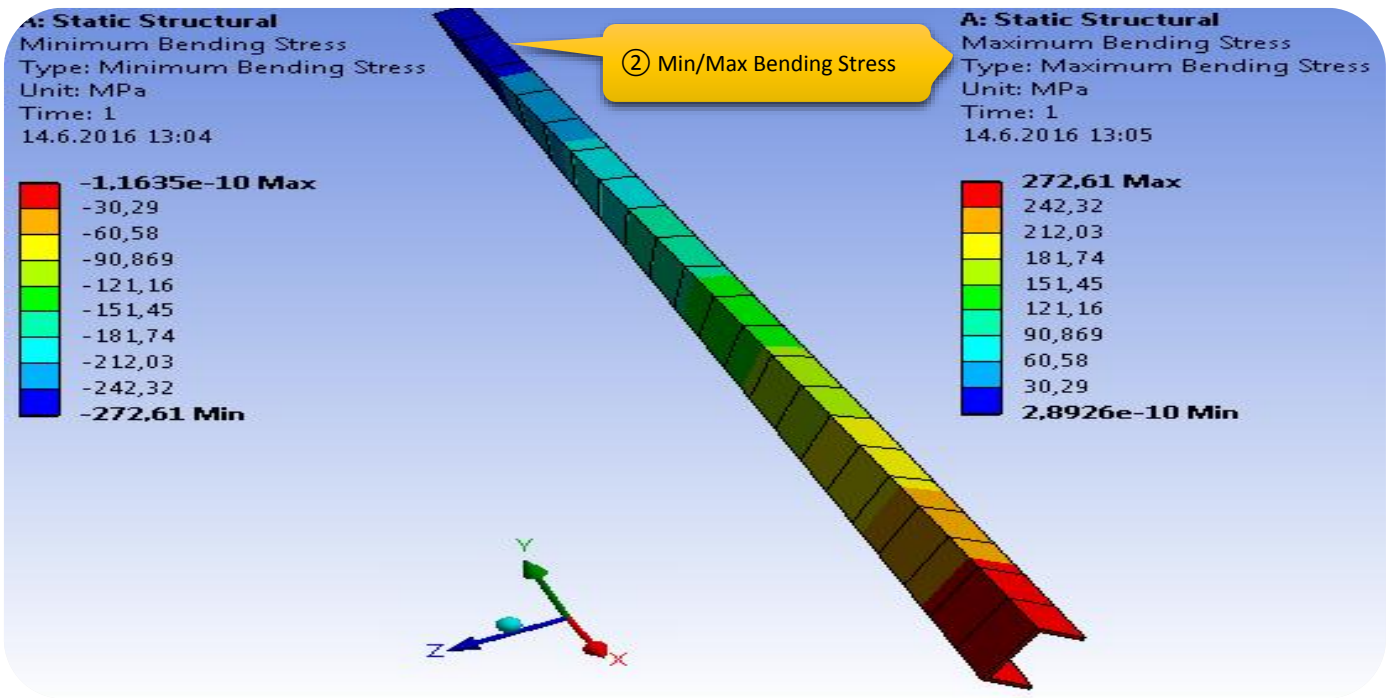
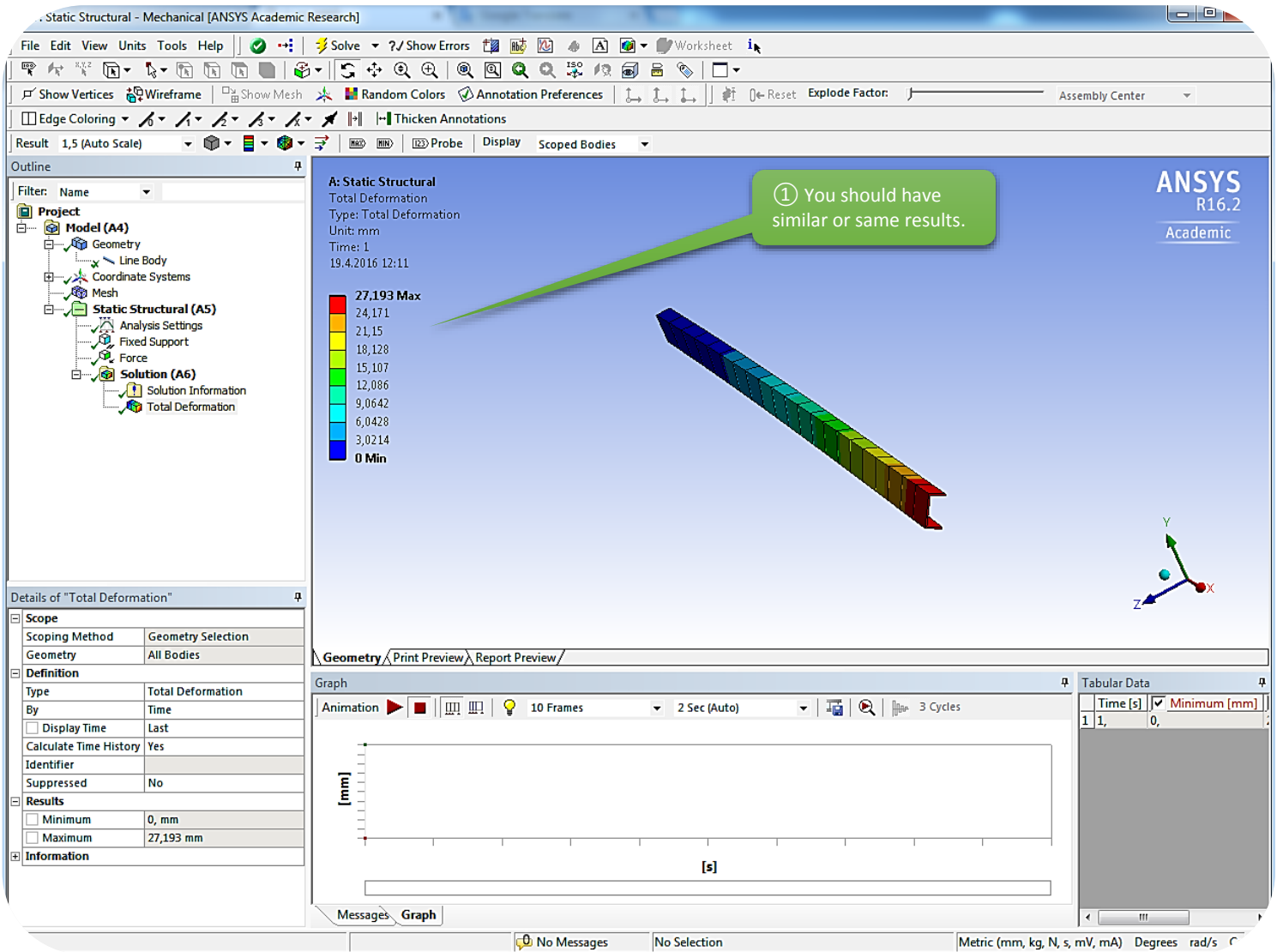

## CHAPTER\_II: BEAM SYSTEM

## 2.1 Problem Description

In this chapter we are asked to create a 3D Cube Beam System. The Cube Beam System has a square cross-section which is given below.

# Inputs →

**Material**

Structural Steel: Young's Modulus = 200 GPa;

Poisson's Ratio = 0.3;

**Dimensions**

$l = 100 \text{ mm};$

$F_1 = 150 \text{ N};$

$a = 8 \text{ mm};$

$F_2 = 200 \text{ N};$

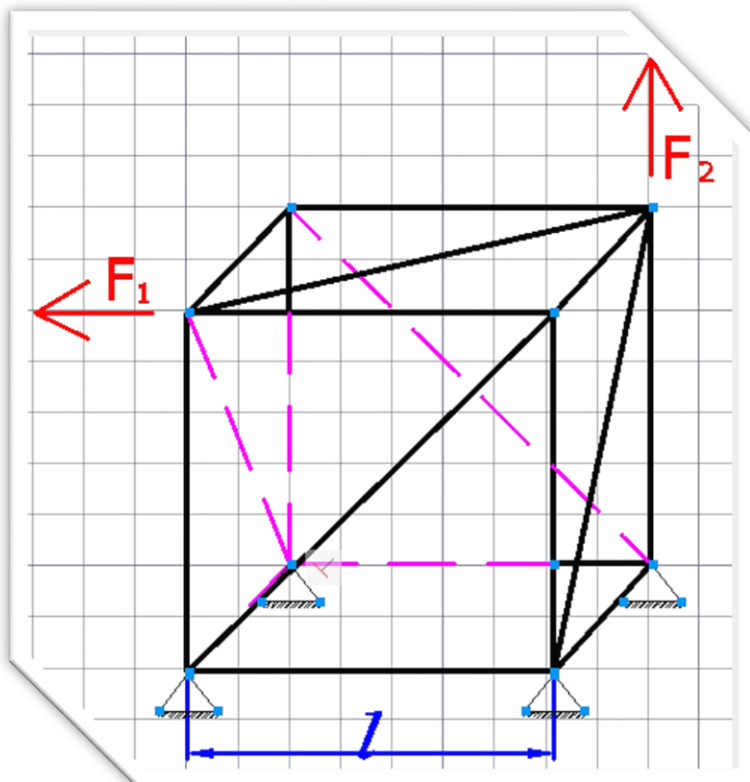
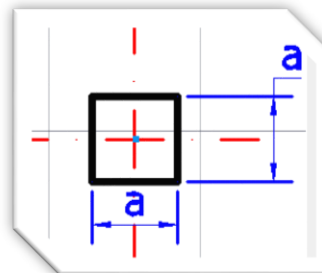
**Square Cross-Section**

## 2.2 Start-Up

As we progress forward to more complicated tasks/geometries, the steps that we were explaining so detailed in the previous chapters won't be explicated as much.

The screenshot displays the ANSYS Workbench interface. On the left is the 'Toolbox' containing various analysis systems. The 'Project Schematic' on the right shows a hierarchy starting with 'A' (Assembly) containing '1 Static Structural', '2 Engineering Data', '3 Geometry', '4 Model', '5 Setup', '6 Solution', and '7 Results'. The 'Static Structural' component is highlighted in blue. An orange callout points to the 'Static Structural' icon in the toolbox. A green callout points to the 'Project' menu. A blue callout points to the 'Engineering Data' component in the schematic. A black callout points to the 'Static Structural' component in the schematic.

① Launch Workbench and save the project as "Beam Cube".

② Create a Static Structural System.

③ Double-click on Engineering Data to check Material Properties.

④ Start up Design Modeler and select "millimeters" as length unit.

## 2.3 Create Body

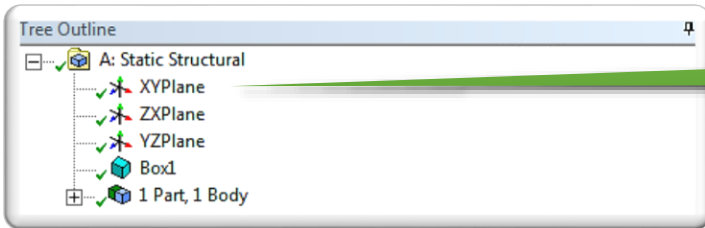

① Select XYPlane, go to Create/ Primitives/ Box.

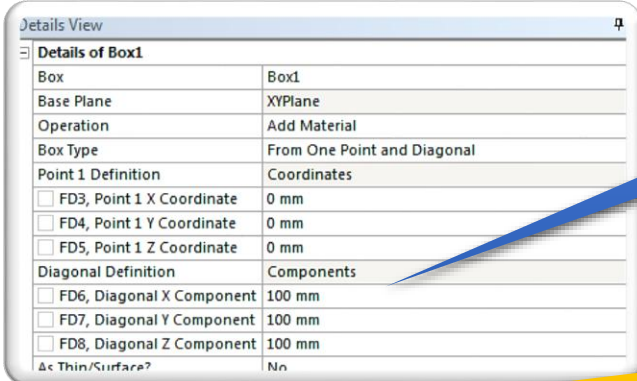

② Change the dimensions according to our data.

③ Click Generate.

④ Graphic View.

Generate

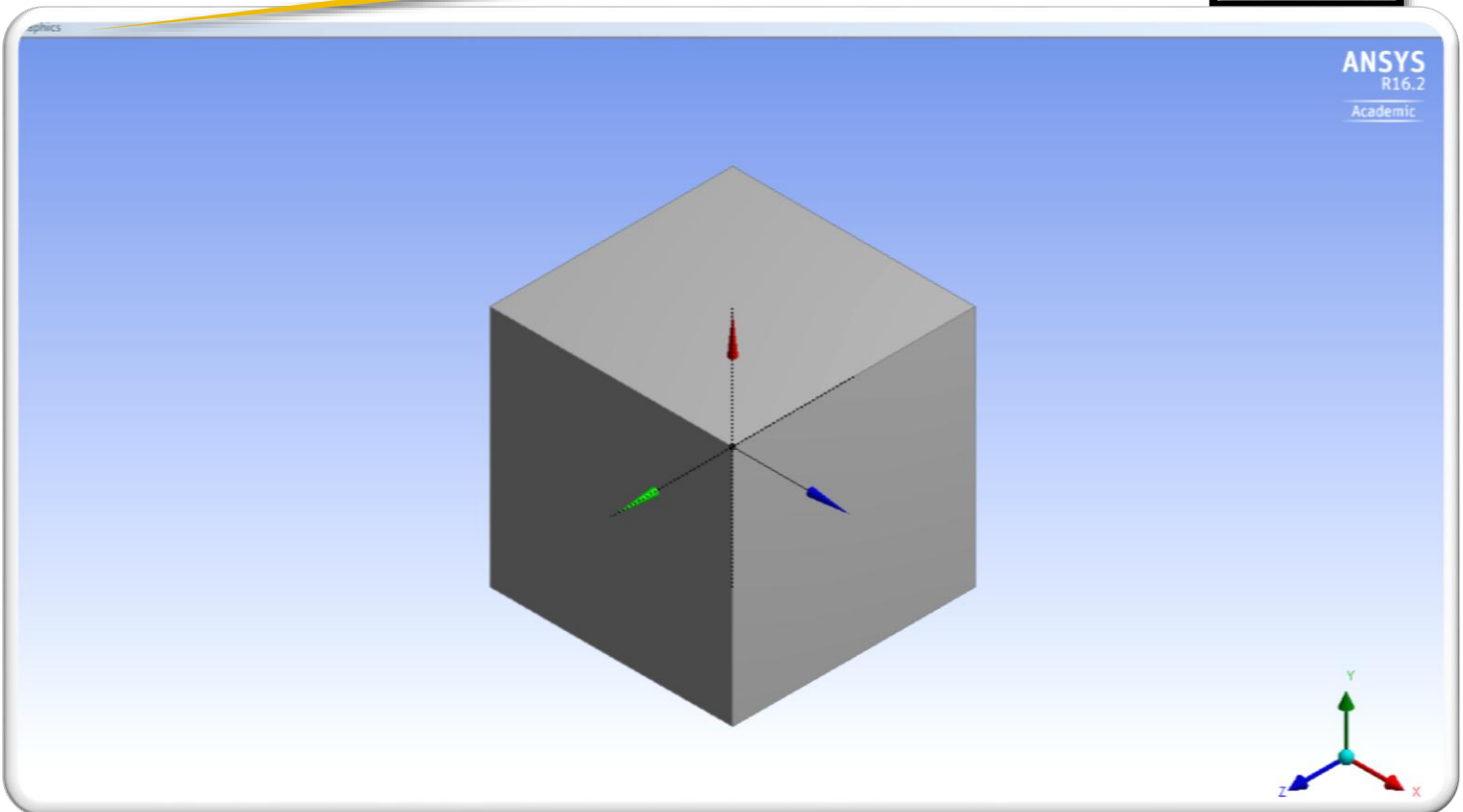

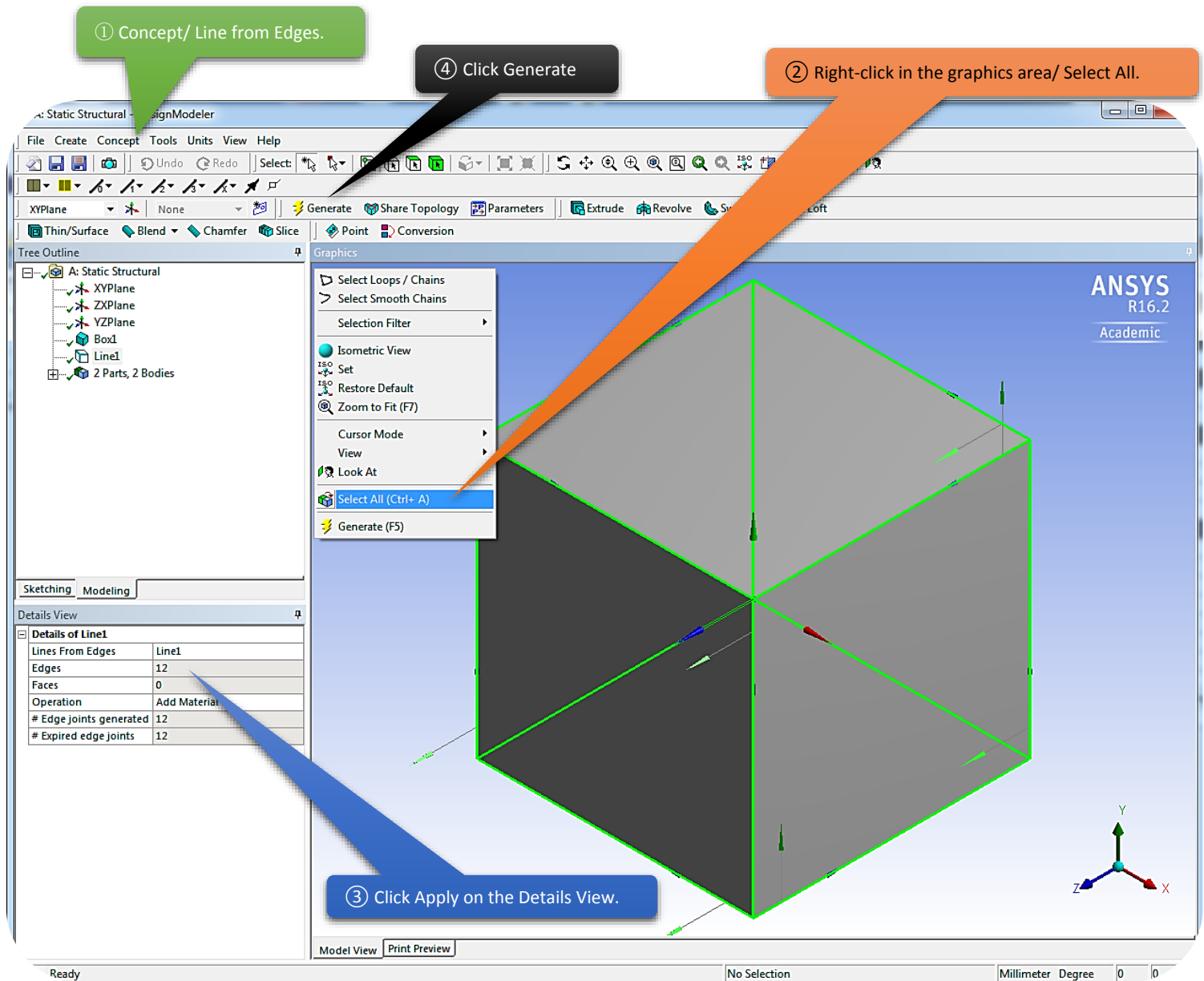

- The **Lines From Edges** feature allows the creation of Line Bodies in ANSYS DesignModeler that are based on existing model edges. The feature can produce multiple line bodies, depending on the connectivity of the selected edges and faces. Select 3D model edges, and faces through two Apply/Cancel button properties.

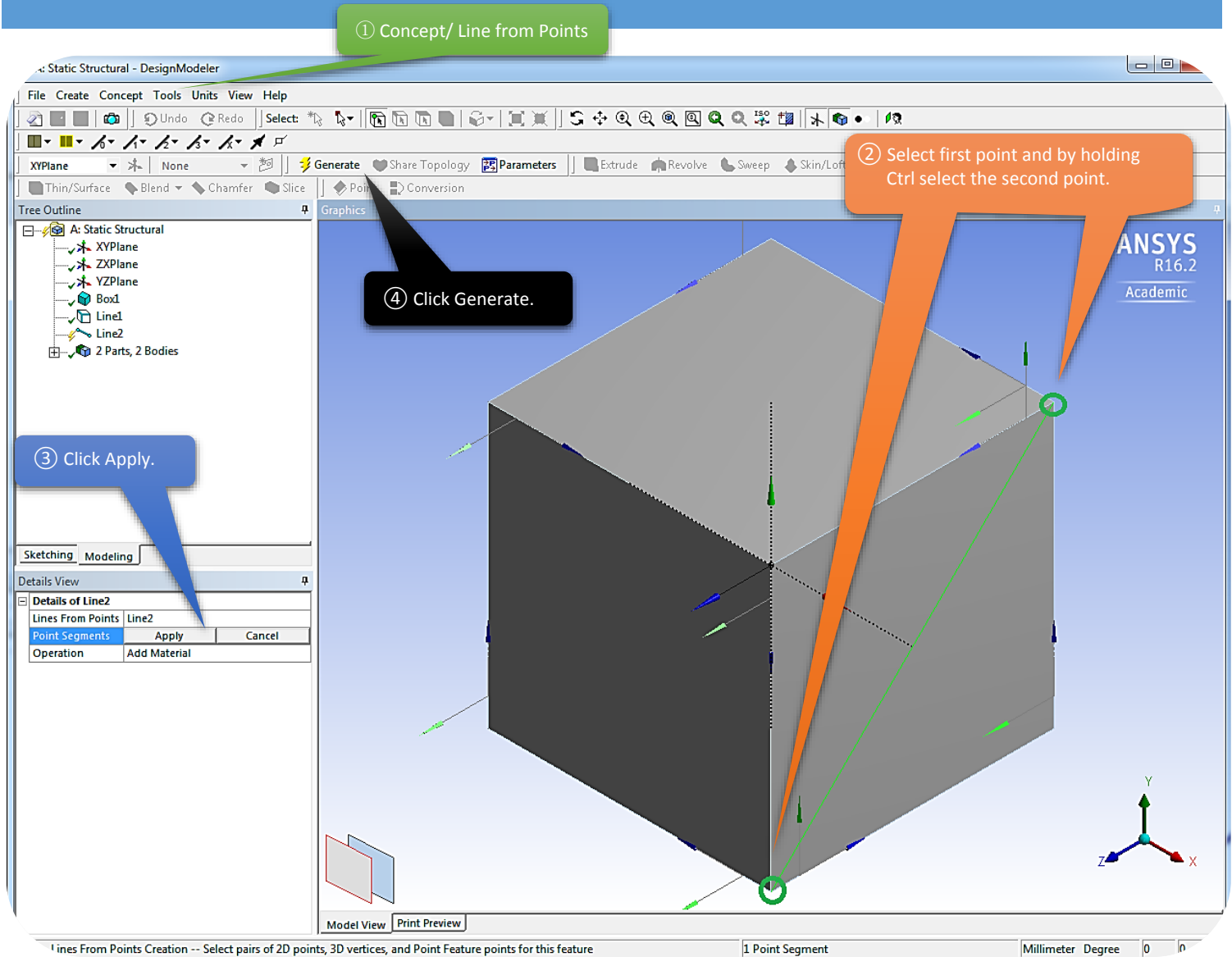

⑤ Repeat the same steps to create our geometry and eventually you should have the exact cube as shown in the figures below.

- The **Lines From Points** feature allows the creation of Line Bodies in ANSYS DesignModeler that are based on existing points. Points can be any 2D sketch points, 3D model vertices, and point feature points (PF points). The feature's selections are defined by a collection of point segments. A point segment is a straight line connecting two selected points. The feature can produce multiple line bodies, depending on the connectivity of the chosen point segments. The formation of point segments is handled through an Apply/Cancel button property.

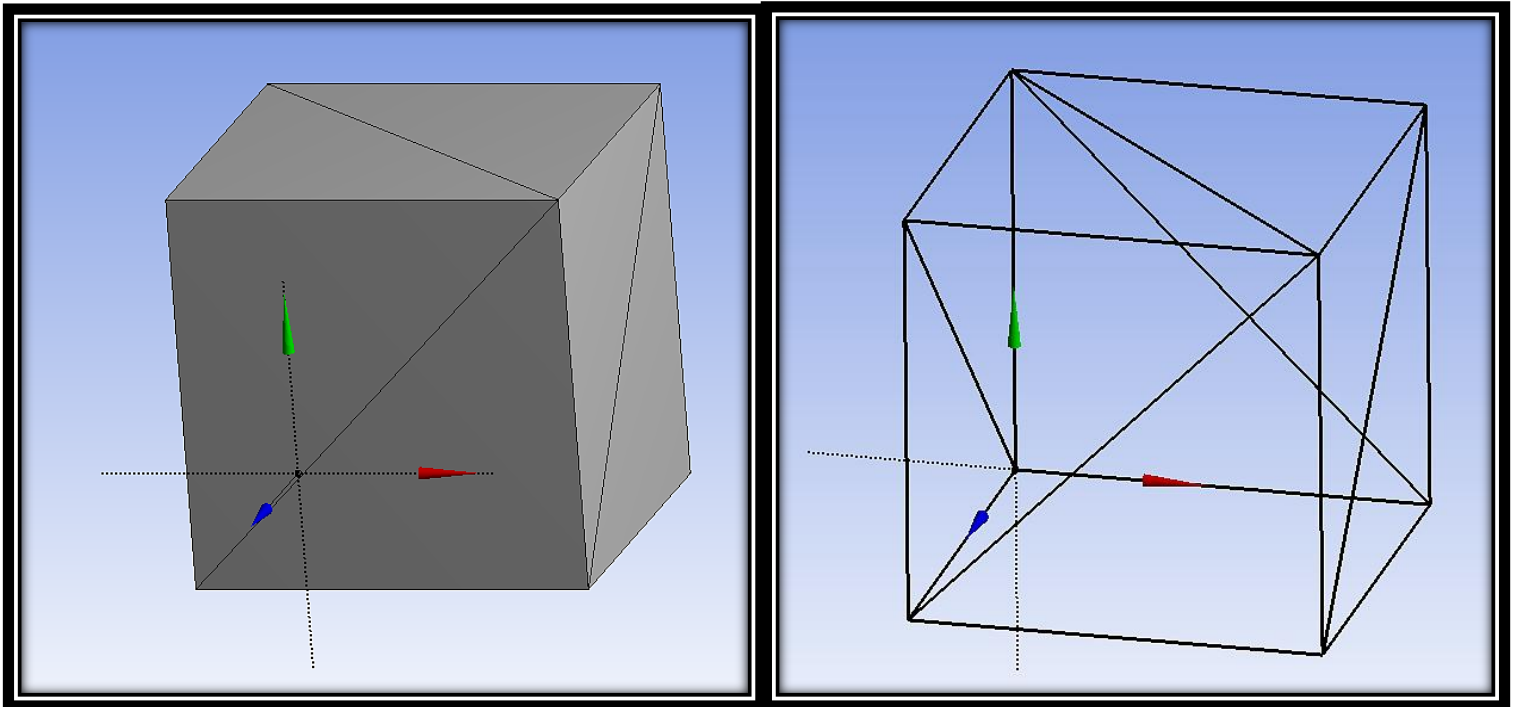

*Whole Solid Body View*

*Suppressed Body View*

- After you are done sketching, right-click on Solid → choose suppress body and you should have the same looks as above.

### 2.4 Create Cross-Section

① Pull down Concept/ Cross-Section/ Rectangular.

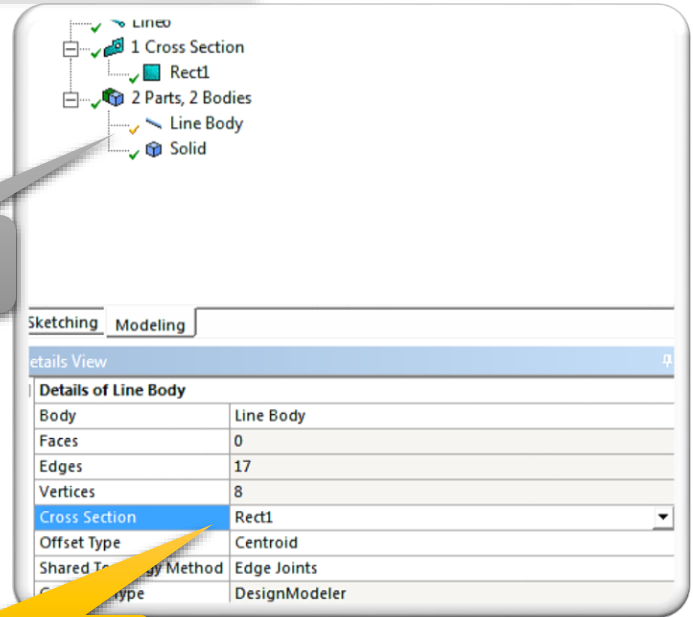
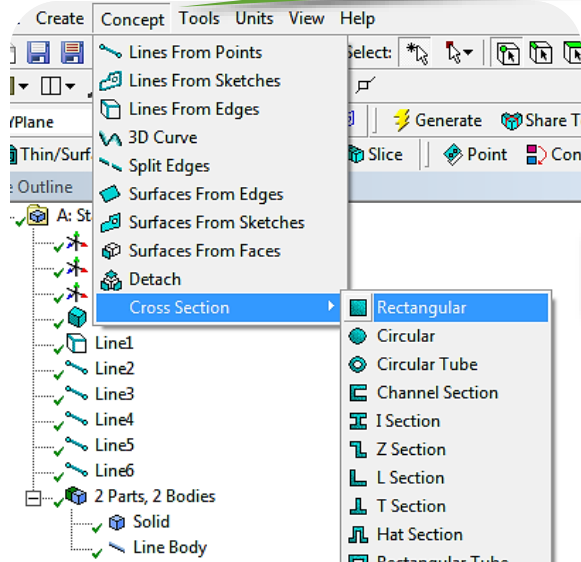

④ Select Line Body.

② Fill in our dimensions for the rectangular cross-section.

⑤ Select Cross-Section Rect1.



⑧ Our cube body with default cross section alignments.

③ Cross-Section View.

⑥ Turn on View/ Cross Section Solids.

⑦ Turn on View/ Cross Section Alignments.

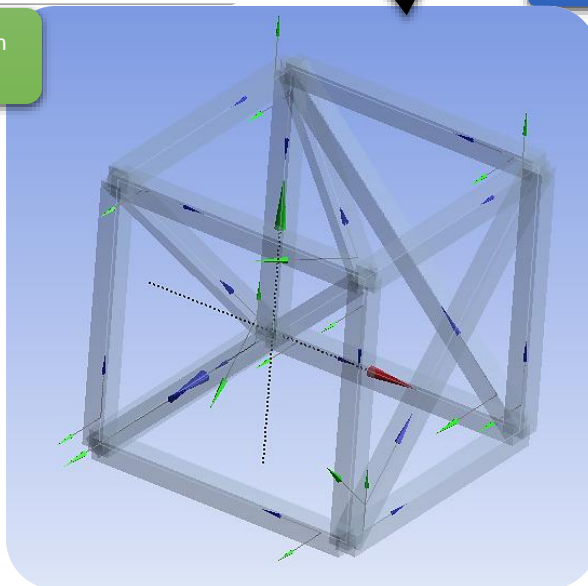
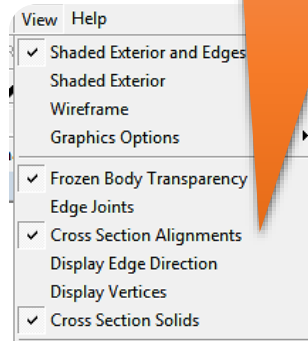
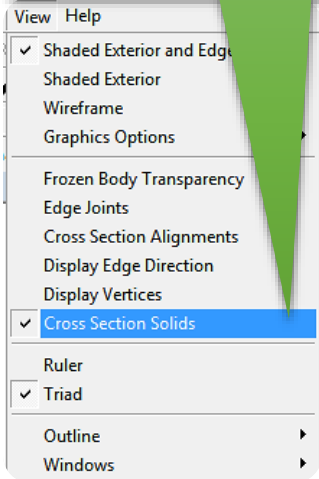

⑨ Enlarge to see details.

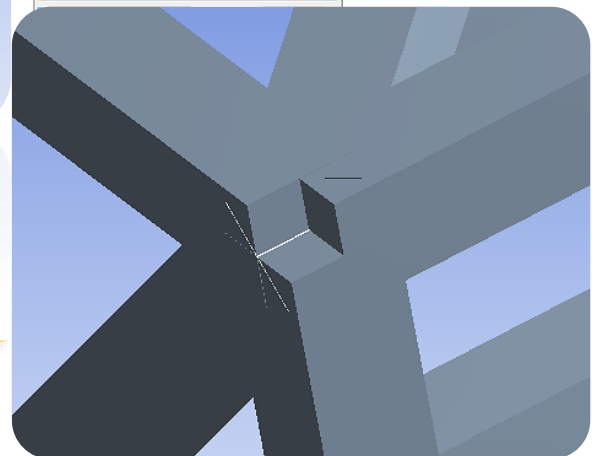

**Cross-Section Alignments**

The default cross section alignments usually need to be adjusted so that they are consistent with the reality. In this chapter we decided to leave them default. In other words cross section alignments do not affect the structural response too much in this case.

**2.5 Start-up “Mechanical”**

① Close Design Modeler.

② Double-click Model to start the Mechanical.

③ Change or leave default the unit system.

**2.6 Generate Mesh**

① Right-click on Mesh.

② Generate Mesh.

③ After generating mesh, this is your displayed Mesh.

## 2.7 Specify Boundary Conditions

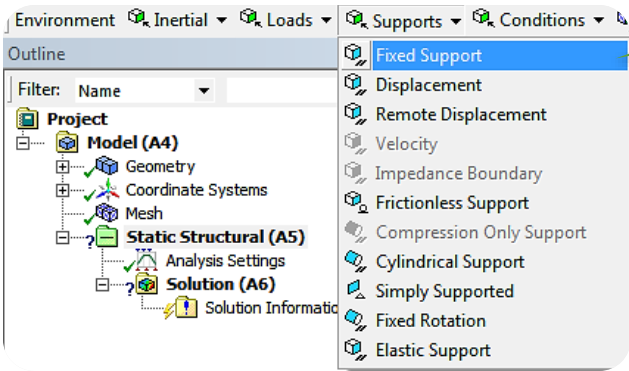

① Highlight Static Structural in the project tree and select Supports/ Fixed Support.

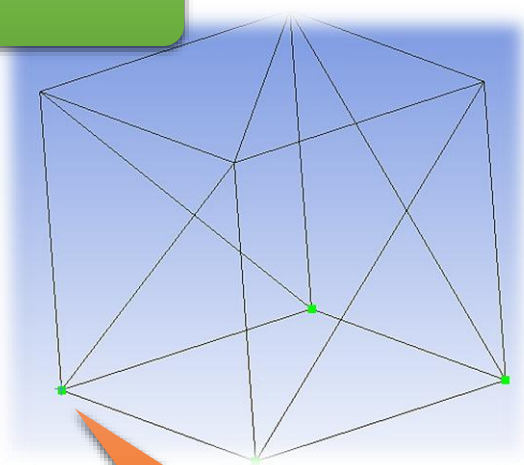

② Select the 4 vertices at the vase. You may need to turn on/select vertex select filter.

Details of "Fixed Support"	
<b>Scope</b>	
Scoping Method	Geometry Selection
Geometry	Apply
<b>Definition</b>	
Type	Fixed Support
Suppressed	No

③ Click Apply.

## 2.8 Specify Loads

① Select Loads/ Force, having highlighted Static Structural.

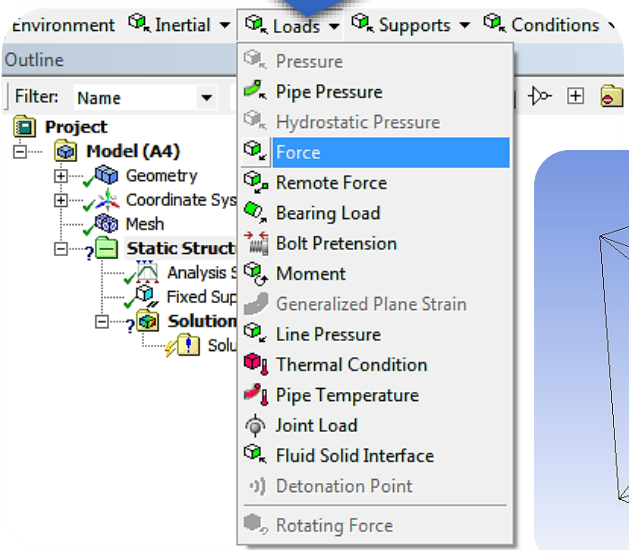

② Select P1 and click Apply.

Details of "Force"	
<b>Scope</b>	
Scoping Method	Geometry Selection
Geometry	1 Vertex
<b>Definition</b>	
Type	Force
Define By	Components
Coordinate System	Global Coordinate System
<input type="checkbox"/> X Component	0, N (ramped)
<input type="checkbox"/> Y Component	0, N (ramped)
<input checked="" type="checkbox"/> Z Component	150, N (ramped)
Suppressed	No

③ Input the correct data as shown on the figure.

④ Follow ①, select P2 and click Apply

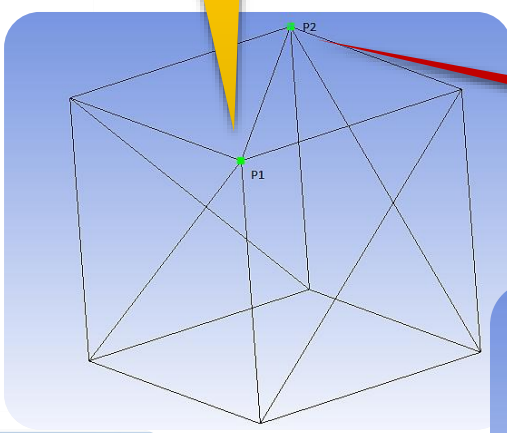

Details of "Force 2"	
<b>Scope</b>	
Scoping Method	Geometry Selection
Geometry	1 Vertex
<b>Definition</b>	
Type	Force
Define By	Components
Coordinate System	Global Coordinate System
<input type="checkbox"/> X Component	0, N (ramped)
<input checked="" type="checkbox"/> Y Component	200, N (ramped)
<input type="checkbox"/> Z Component	0, N (ramped)
Suppressed	No

⑤ Input the correct data as shown on the figure.

⑥ Final figure, showing the boundary conditions and the forces.

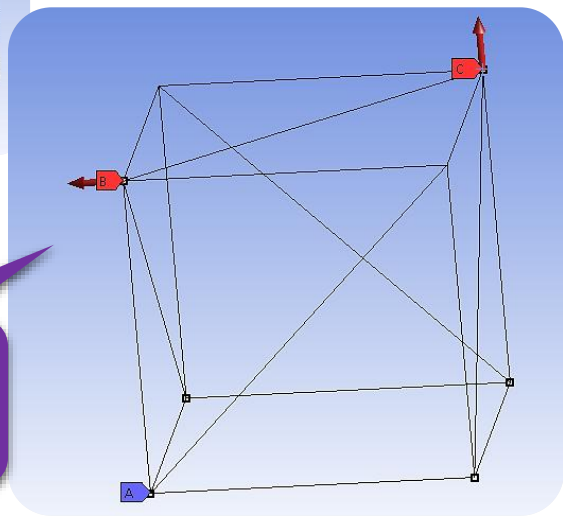

### 2.9 Set up Solution Branch and Solve the Model

⑤ Click Solve.

① Highlight Solution Branch.

② Select Deformation/ Total.

③ Select Tools/ Beam Tool.

④ Outline View.

The screenshot shows the ANSYS Workbench interface. The Outline view on the left shows a project structure with a Solution branch (A6) containing Solution Information, Total Deformation, and Beam Tool. The Solution branch is highlighted. The Tools palette on the right shows the Beam Tool selected. The Deformation palette shows Total selected. A 'Solve' button is visible at the top left.

### 2.10 View the Results

① Maximum Deformation = 0.0045 mm

② Maximum Direct Stress = 3.48 MPa

The left screenshot shows the Total Deformation result for a static structural analysis. The maximum deformation is 0.0045655 mm. The right screenshot shows the Direct Stress result for the same analysis. The maximum direct stress is 3.4848 MPa. Both results are displayed as 3D models of a beam system with a color scale indicating the magnitude of the results.

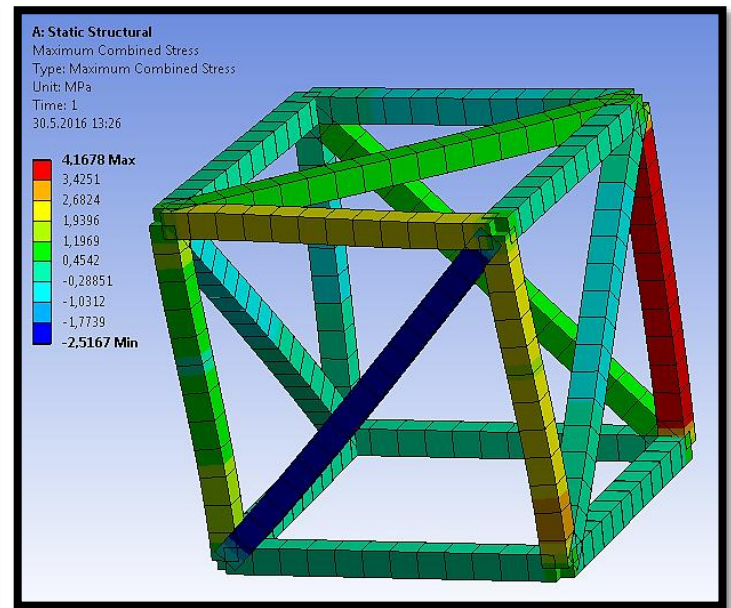
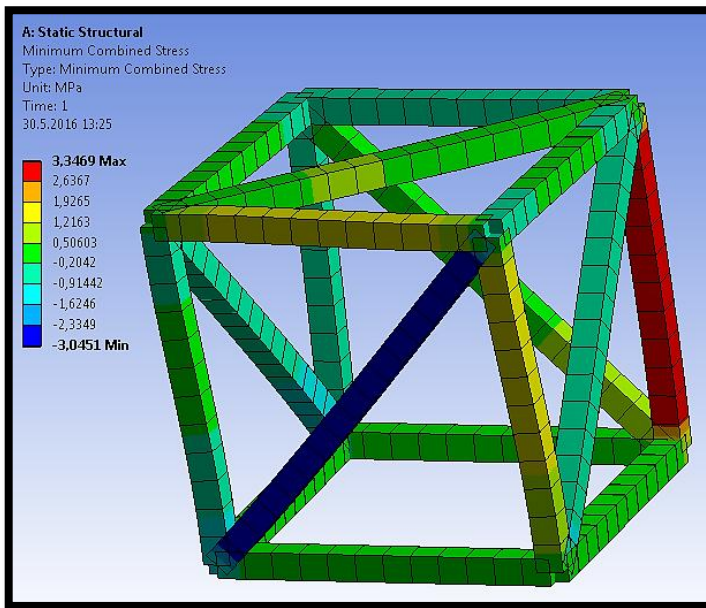

The combined stress ranges from -3.9 MPa to 4.2 MPa.

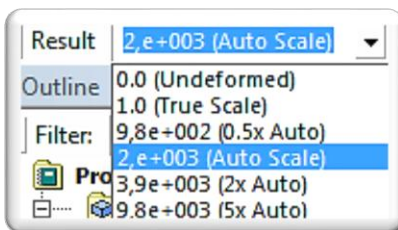

③ Changing the result scale will make the animation more obvious.

## CHAPTER\_III: PLATE

## 3.1 Problem Description

In this chapter we are interested to know the concepts of Finite Element Simulation, like “*Stress Discontinuity*”, “*Structural Error*”, “*Stress Singularity*”, “*Finite Element Convergence*”.

To demonstrate this concepts we are going to use a Plate geometry with notch, which is made out of steel and has the given dimensions. The bar has Fixed Support on the left side and is subject to a tension of 50MPa on the right side.

# Input →

**Material**

Structural Steel: Young's Modulus = 200 GPa;

Poisson's Ratio = 0.3;

**Dimensions**

$l = 100 \text{ mm};$      $t = 10 \text{ mm};$      $a = 50 \text{ mm [a]};$

$R = 15 \text{ mm};$      $b = 25 \text{ mm};$      $F = 50 \text{ N};$

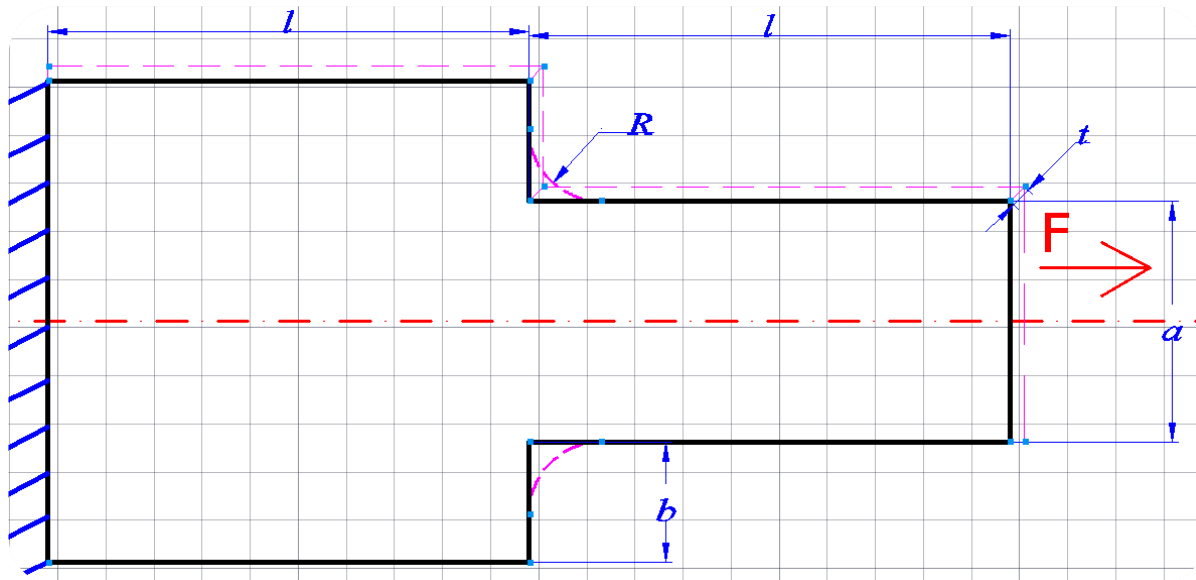

### 3.2 Start-Up

- Launch Workbench, create a Static Structural system by choosing it from the list on the left (toolbox). Save the project before we begin, to an appropriate location and name.

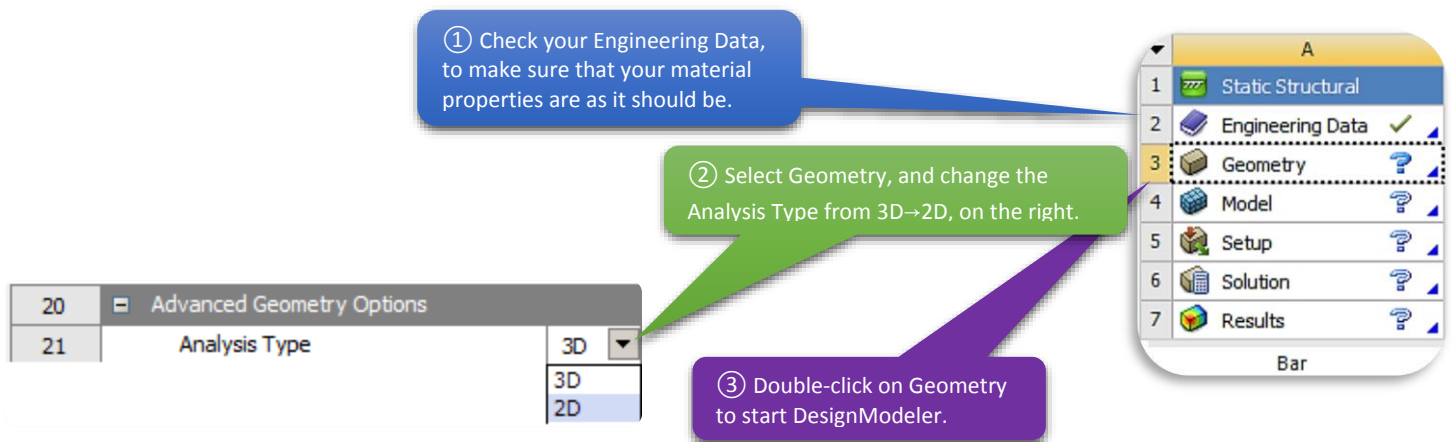

- As soon as DesignModeler opens, go to Units and select Millimeters.

### 3.3 Creating the 2D Geometry Model

- Let's start creating our Geometry. Choose XYPlane as your sketch plane, open Sketching tab and create our Plate Bar.

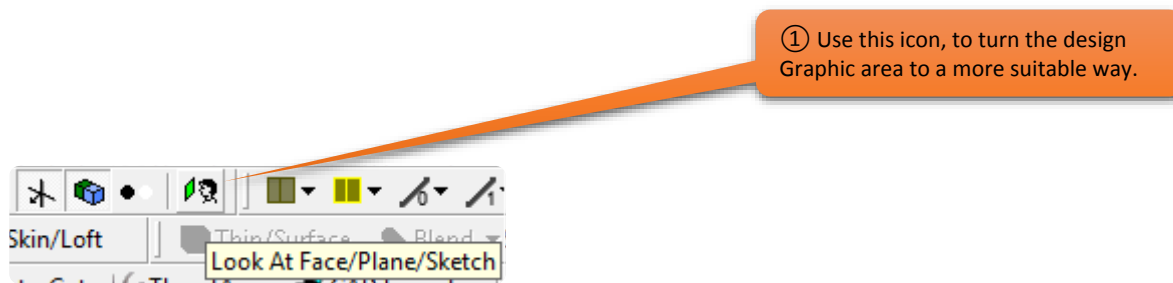

*When you select Draw → Line and move your mouse to the Graphic area, you will notice that in certain positions the mouse pointer will present different letter, depending on the position which the pointer is.*

H → Horizontal    P → Point  
V → Vertical      C → Center

*Our Geometry is Symmetrical, which means that we will only sketch half of the drawing and then when we are done we will use Mirror command to create the other half.*

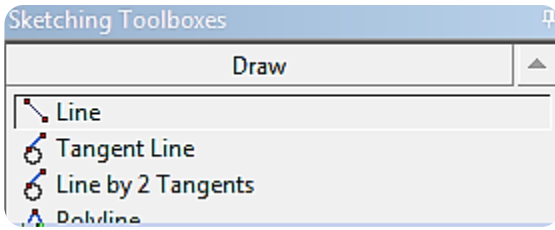

② Go to Draw/ Line and sketch this Geometry.

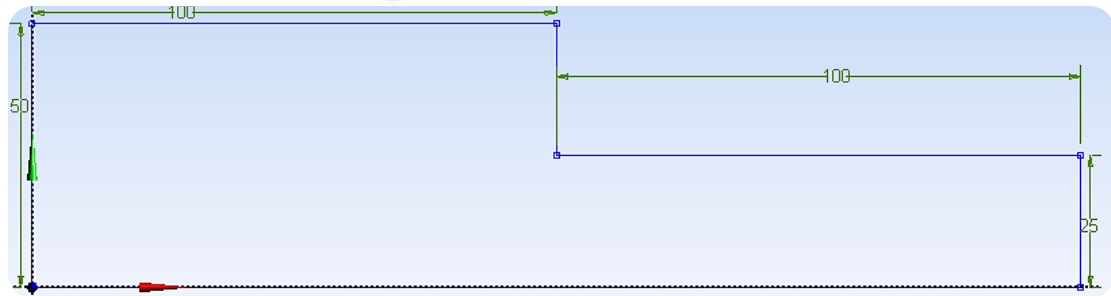
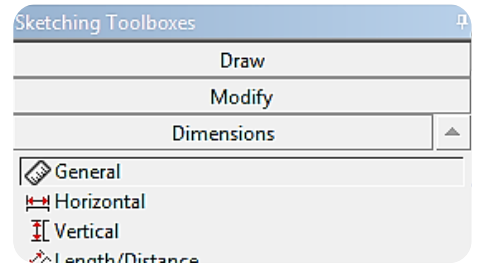

Details View

Details of Sketch1	
Sketch	Sketch1
Sketch Visibility	Show Sketch
Show Constraints?	No
Dimensions: 5	
<input type="checkbox"/> H2	100 mm
<input type="checkbox"/> H8	100 mm
<input type="checkbox"/> R6	15 mm
<input type="checkbox"/> V1	50 mm
<input type="checkbox"/> V4	25 mm

③ Go to Dimensions/ General and assign the dimensions according to our data.

④ Go back to Modelling Tree

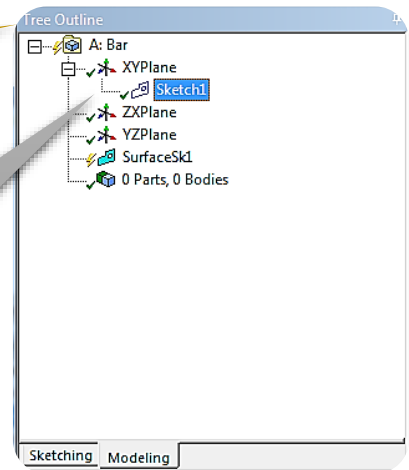

⑥ Select Sketch1 for Base Objects.

⑤ Select Concept/ Surface from Sketches.

Details View

Details of SurfaceSk1	
Surface From Sketches	SurfaceSk1
Base Objects	Apply Cancel
Operation	Add Material
Orient With Plane Normal?	Yes
Thickness (>=0)	10 mm

⑦ Thickness = 10 mm.

⑧ Click on Generate.



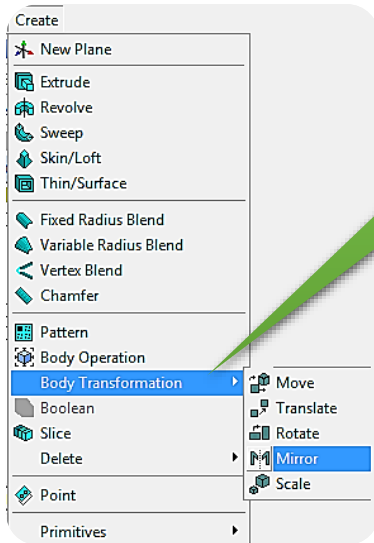

⑤ Go to Create/ Body Transformation/ Mirror.

⑥ For Mirror Plane choose ZXPlane from the Tree Outline.

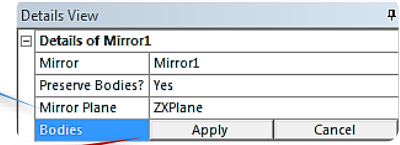
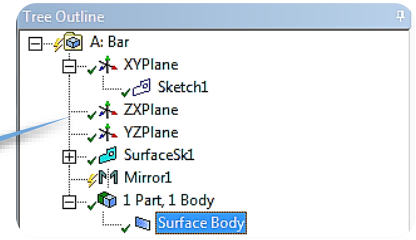

⑧ Click Apply.

⑦ For Bodies, choose our Surface Body.

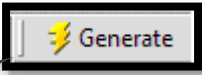
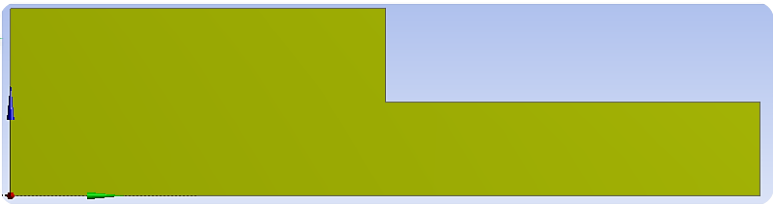

⑨ Click on Generate.

⑩ End result.

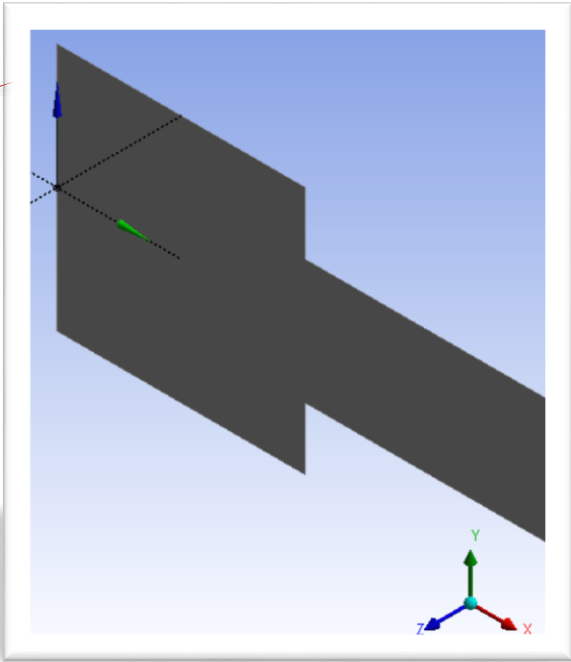

### 3.4 Set Up Mesh Controls

① Open up Mechanical by double-clicking on Model.

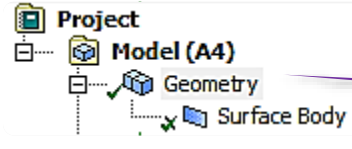
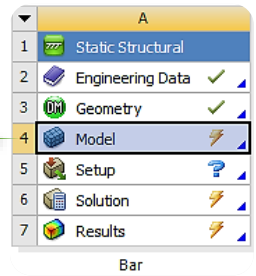

② Before getting to the next steps, highlight Geometry.

③ And make sure 2D Behavior is set to Plane Stress.

Details of "Geometry"	
<b>Definition</b>	
Source	C:\Users\kubik\Desktop\Course_Book\ANSYS_Wb\Task_III\...
Type	DesignModeler
Length Unit	Meters
Element Control	Program Controlled
2D Behavior	Plane Stress
Display Style	Body Color

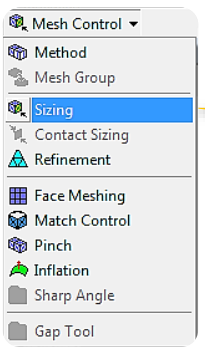

④ Go to Mesh Control/ Sizing.



⑤ Change your selection to Vertex/Node.

Details of "Vertex Sizing" - Sizing	
<b>Scope</b>	
Scoping Method	Geometry Selection
Geometry	1 Vertex
<b>Definition</b>	
Suppressed	No
Type	Sphere of Influence
<input type="checkbox"/> Sphere Radius	20, mm
<input checked="" type="checkbox"/> Element Size	2, mm

⑥ For Geometry, choose the sharp corner where the two lines meet.

⑦ Input Sphere Radius and Element Size.

# Right-click on Mesh/ Generate Mesh.

### 3.5 Set Up Supports, Loads

**Units**

- Metric (m, kg, N, s, V, A)
- Metric (cm, g, dyne, s, V, A)
- Metric (mm, kg, N, s, mV, mA)**
- Metric (mm, t, N, s, mV, mA)
- Metric (mm, dat, N, s, mV, mA)
- Metric (μm, kg, μN, s, V, mA)
- U.S. Customary (ft, lbm, lbf, °F, s, V, A)
- U.S. Customary (in, lbf, °F, s, V, A)

Degrees

Radians

rad/s

RPM

Celsius (For Metric Systems)

Kelvin (For Metric Systems)

① Make sure "Metric" units are selected.

② Supports/Fixed Support on the left side.

**Details of "Fixed Support"**

Scope	
Scoping Method	Geometry Selection
Geometry	Apply Cancel
Definition	
Type	Fixed Support
Suppressed	No

**Supports**

- Fixed Support**
- Displacement
- Remote Displacement
- Velocity
- Impedance Boundary
- Frictionless Support
- Compression Only Support
- Cylindrical Support
- Simply Supported
- Fixed Rotation
- Elastic Support

③ Loads/ Pressure of 50 MPa to X Component on the right side.

**Loads**

- Pressure**
- Pipe Pressure
- Hydrostatic Pressure
- Force
- Remote Force
- Bearing Load
- Bolt Pretension
- Moment
- Generalized Plane Strain
- Line Pressure
- Thermal Condition
- Pipe Temperature
- Joint Load
- Fluid Solid Interface
- Detonation Point
- Rotating Force

**Details of "Pressure"**

Geometry	1 Face
Definition	
Type	Pressure
Define By	Components
Coordinate System	Global Coordinate System
<input type="checkbox"/> X Component	50. MPa (ramped)
<input checked="" type="checkbox"/> Y Component	0. MPa (ramped)
<input type="checkbox"/> Z Component	0. MPa (ramped)
Suppressed	No

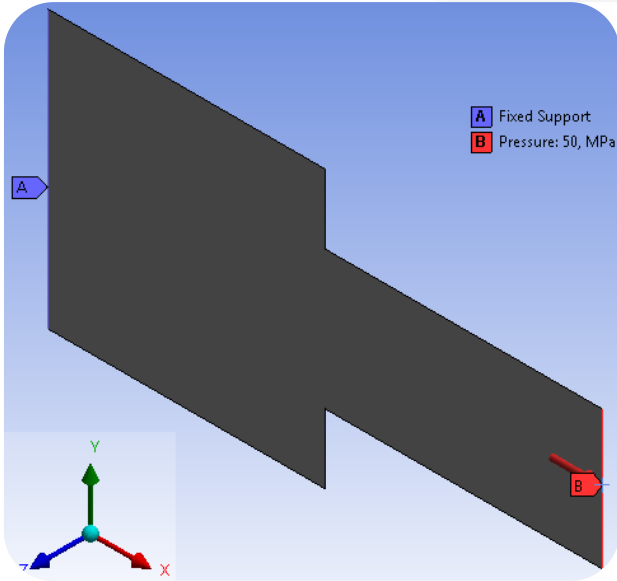

### 3.6 Set Up Solution Outcome Branch

① Insert Deformation/ Directional Deformation.

② Insert Stress/ Normal Stress twice.

③ One Averaged Normal Stress, and the other one will be Unaveraged.

**Details of "Normal Stress 2"**

By	Time
<input type="checkbox"/> Display Time	Last
Coordinate System	Global Coordinate System
Calculate Time History	Yes
Identifier	
Suppressed	No
<b>Integration Point Results</b>	
Display Option	Averaged
Average Across Bodies	No

**Deformation**

- Total
- Directional**
- Total Velocity
- Directional Velocity
- Total Acceleration
- Directional Acceleration

**Stress**

- Equivalent (von-Mises)
- Maximum Principal
- Middle Principal
- Minimum Principal
- Maximum Shear
- Intensity
- Normal**
- Shear
- Vector Principal
- Error
- Membrane Stress
- Bending Stress

**Solution (A6)**

- Solution Information
- Directional Deformation
- Normal Stress
- Normal Stress 2, Unaveraged**

④ Click on Solve.

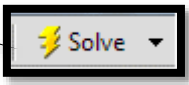

### 3.7 View the Results

The displacements fields are continuous but not necessarily smooth, as you can see from the figure, the displacement is more intensive at the right than the left side of our geometry. The use of continuous shape elements guarantees that the displacement field is smooth, but not so much at the element boundaries.

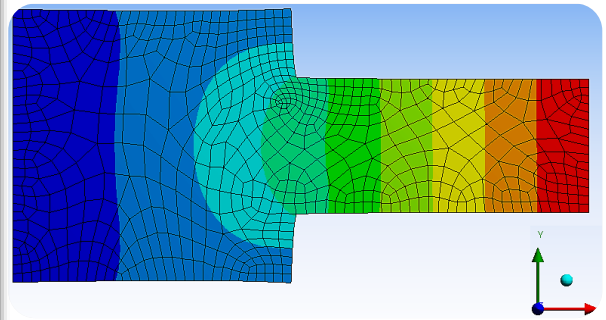
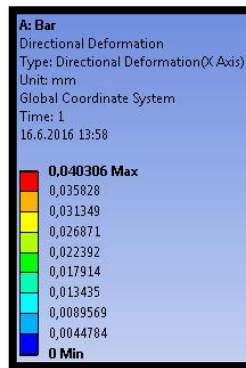

The calculations are element-by-element. The figure in the right is a typical result of stress calculation. Note that a node may have multiple stress values, since the node may connect to multiple elements, and each element calculation results a value. By default, stresses are averaged on the nodes, and the stress field is recalculated.

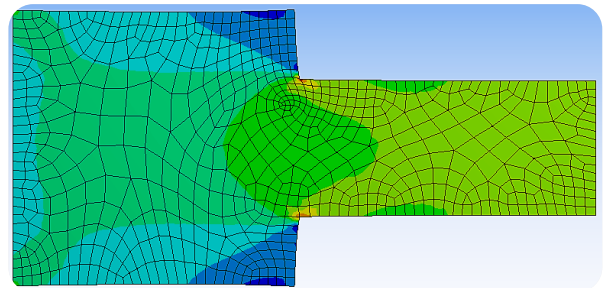
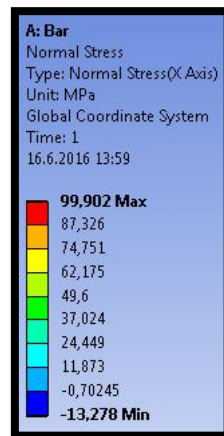

The averaged stress fields are visually efficient for human eyes to interpret the results, while unaveraged stress fields provide a way of assessing the solution accuracy.

In general, as the mesh is getting finer the solution is more accurate, and the stress discontinuity (could be checked as a difference between Averaged and Unaveraged results) is less obvious. The less discontinuous of the stress field, the more accurate of the solution.

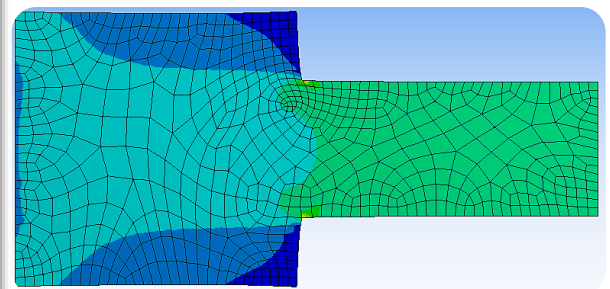
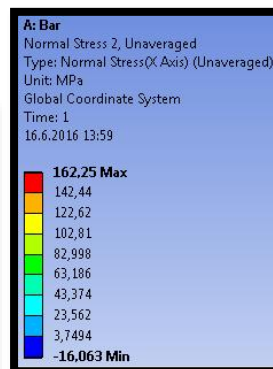

## 3.7.1 Perform Simulations

In section 3.4, we set up the Mesh controls, including Sphere Radius and Element Size. The reason we did that was to make the mesh finer in a specific area of our geometry so that the results in that area would be more accurate. In this section we are going to run multiple simulations making the mesh in that point increasingly finer.

As we proceed we will change the Element Size and the Sphere Radius, and see how it affects our results.

**Hint:**

Stress singularity is not limited to sharp corners. Any locations that have stress of infinity are called singular points.

Element Size [mm]	Sphere Radius [mm]	Max Normal Stress [X Axis][MPa]
<b>2</b>	20	99.902
<b>1</b>	10	132.1
<b>0.5</b>	5	172.8
<b>0.2</b>	2	286.56
<b>0.1</b>	2	423.31

You can see from the results of Maximum Normal Stress, that each time that we decrease Element Size and Sphere Radius (meaning that the mesh is getting finer) the difference between Stresses increases.

For example: First Difference [ 132.1 - 99.9 = ~32MPa]  
 Second Difference [ 172.8 - 132.1 = ~40MPa]  
 Third Difference [ 286.56 - 172.8 = ~100MPa]

We can understand from those results that, the finer the mesh gets, the difference between the two results is getting bigger, theoretically touching infinite.

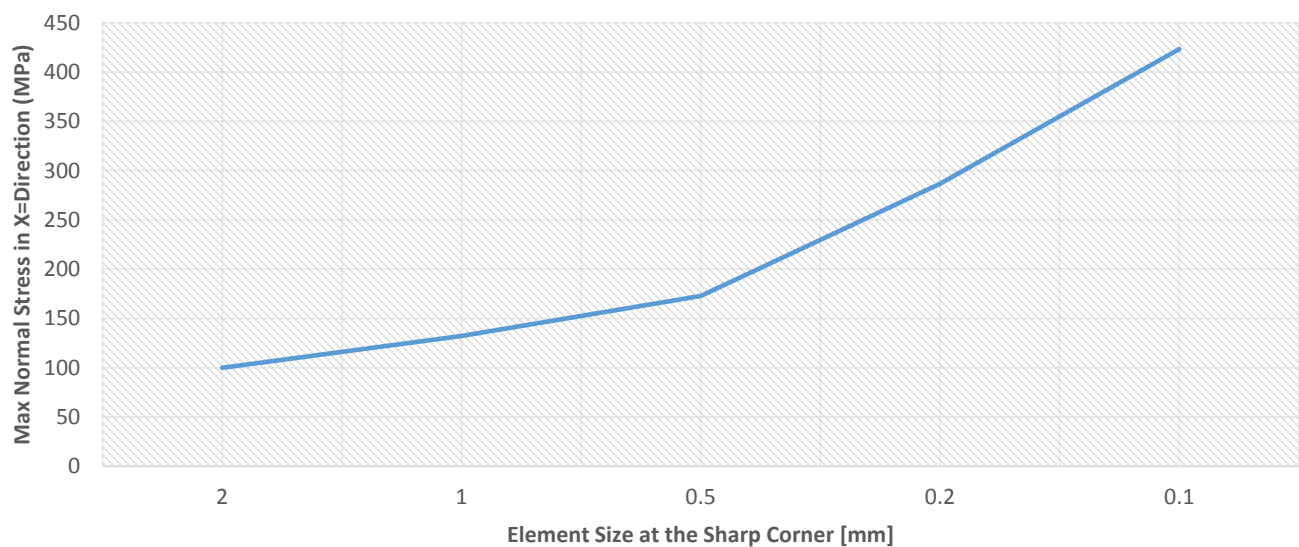

### 3.8 Modify the Model

③ Drag the Geometry tab from the previous system, to the new Static Structural system to modify it.

① Drag and Drop a new Static Structural System.

② Make sure that the new Engineering Data and the Analysis Type (2D) are correct.

⑤ Open Geometry.

④ In order to be able to edit the Geometry you will need to Delete the link between those two systems.

⑦ Go to Modify/ Fillet, and input 15 mm for Radius.

⑥ When DesignModeler opens, choose Sketch1 and head to the Sketching Tab.

⑧ Select the sharp corner to create our fillet.

⑨ Our Fillet is now created, but as you can see, there is only one.

⑩ Go to Modelling tab and click on Generate.

⑪ End Result.

### 3.8.1 Set Up New Supports, Loads

Make sure you got the correct Units selected in the Unit tab. Specify fixed support on the left edge and horizontal force of 50 MPa on the right edge.

Insert Direction Deformation and two Normal Stresses (Averaged and Unaveraged), under the solution branch.

### 3.8.2 Set Up New Mesh Controls

① Highlight Mesh, go to Details of Mesh and change: "Use Advanced Size Function", "Element Size", "Element Midside Nodes".

② Select Mesh Control/ Method.

③ Change Method to Triangles.

④ Click on Solve.

<b>Display</b>	
Display Style	Body Color
<b>Defaults</b>	
Physics Preference	Mechanical
<input type="checkbox"/> Relevance	0
<b>Sizing</b>	
Use Advanced Size Function	Off
Relevance Center	Coarse
<input type="checkbox"/> Element Size	10,0 mm
Initial Size Seed	Active Assembly
Smoothing	Medium
Transition	Fast
Span Angle Center	Coarse
Minimum Edge Length	10,0 mm
<b>Inflation</b>	
<b>Patch Conforming Options</b>	
<b>Patch Independent Options</b>	
<b>Advanced</b>	
Number of CPUs for Parallel Part Meshing	Program Controlled
Shape Checking	Standard Mechanical
Element Midside Nodes	Dropped

<b>Scope</b>	
Scoping Method	Geometry Selection
Geometry	1 Body
<b>Definition</b>	
Suppressed	No
Method	Triangles
Element Midside Nodes	Use Global Setting

### 3.8.3 View the Results

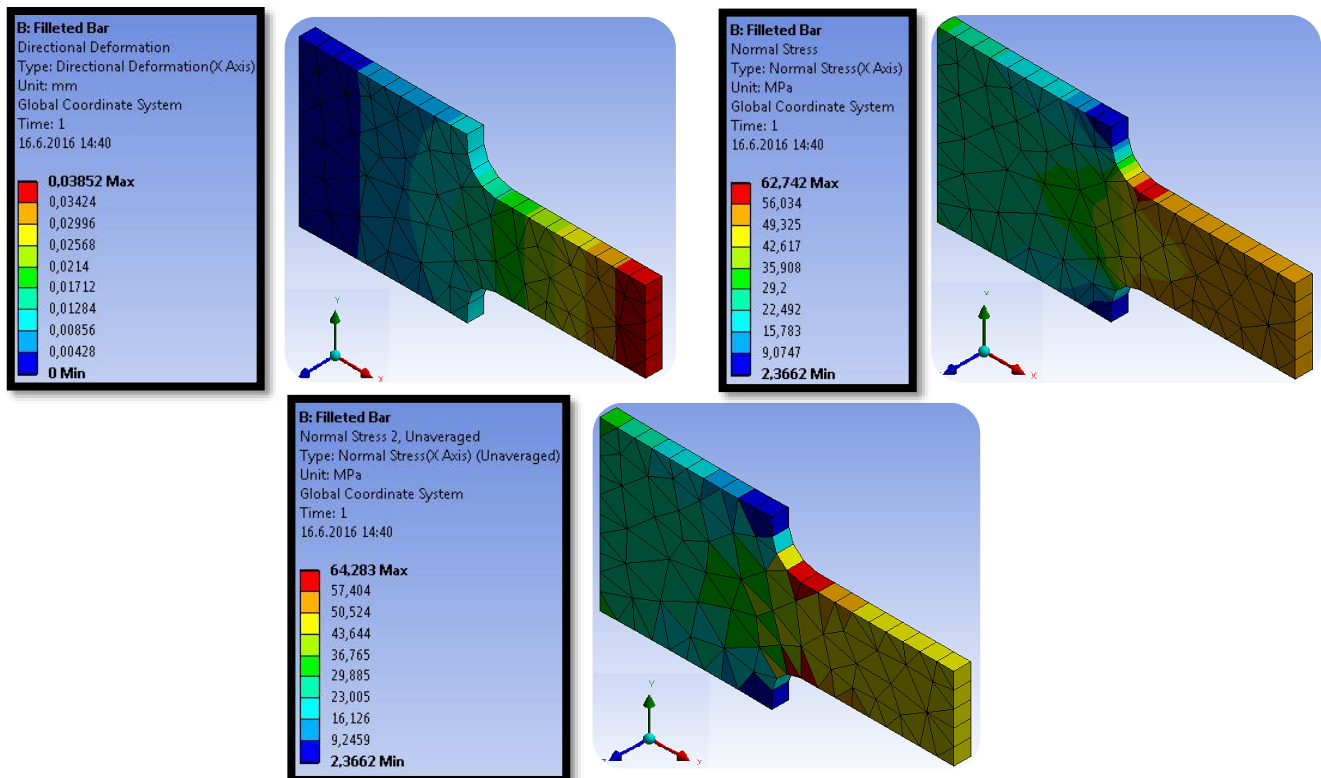

### 3.9 Structural Error

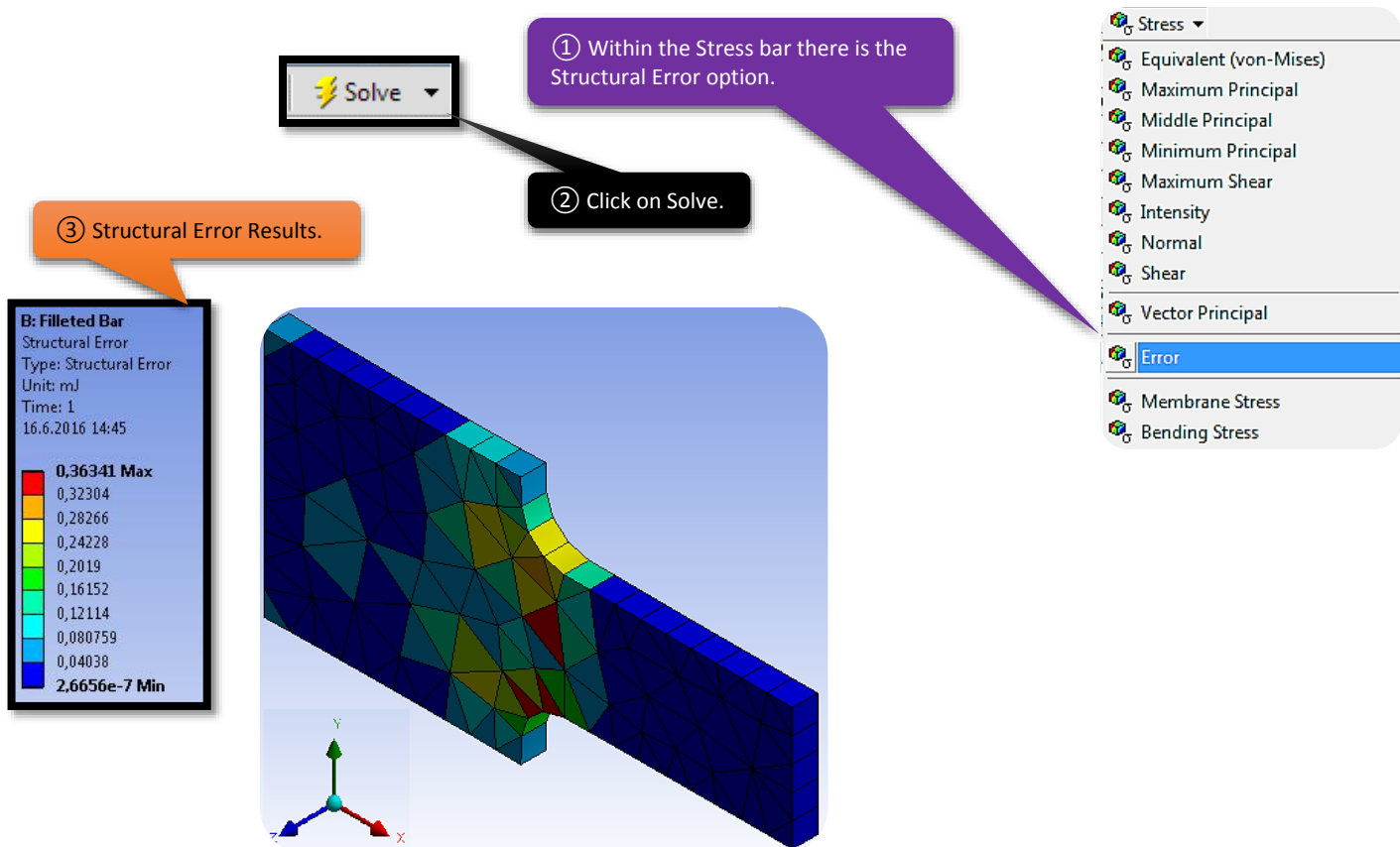

#### Structural Error

For an element, strain energies calculated using averaged stresses and unaveraged stresses respectively are different. The difference between these two energy values is called "Structural Error" of the element. The finer the mesh, the smaller the structural error.

The structural error can be used for two purposes: ① As an indicator of global mesh adequacy and ② As an indicator of the local mesh adequacy.

### 3.10 Finite Element Convergence

One of the core concepts of the finite element method is that, as mentioned, the finer the mesh, the more accurate the solution. Ultimately, the solution will reach the analytical solution. But how fast does it approach that solution? This is what we want to answer in this part of the chapter.

The answer depends on what kind of element we are using. In the next steps we will compare lower-order Triangular with lower-order Quadrilateral elements. The comparison will of course be in the same part of the Geometry so that the results are comparable.

Details of "Automatic Method" - Method	
<b>Scope</b>	
Scoping Method	Geometry Selection
Geometry	1 Body
<b>Definition</b>	
Suppressed	No
Method	Quadrilateral Dominant
Element Midside Nodes	Use Global Setting
Free Face Mesh Type	All Quad

① Repeat the foregoing simulation. Change the Element Size, record the Number of Nodes and the Max. Displacement.

② Change the Method and the Free Face Mesh Type likewise.

Details of "Mesh"	
<b>Display</b>	
<b>Defaults</b>	
<b>Sizing</b>	
Use Advanced Size Function	Off
Relevance Center	Coarse
Element Size	0,50 mm
Initial Size Seed	Active Assembly
Smoothing	Medium
Transition	Fast
Span Angle Center	Coarse
Minimum Edge Length	10,0 mm
<b>Inflation</b>	
<b>Patch Conforming Options</b>	
<b>Patch Independent Options</b>	
<b>Advanced</b>	
<b>Defeaturing</b>	
<b>Statistics</b>	
Nodes	19343
Elements	37508
Mesh Metric	None

③ Repeat → ①.

Element Size [mm]	Number of Nodes	Max Displacement.
10	103	0.03852
6	221	0.038843
3	695	0.039041
1	5027	0.039126
0.5	19343	0.039139

Element Size [mm]	Number of Nodes	Max Displacement.
10	185	0.038947
6	496	0.039066
3	1845	0.039121
1	15470	0.039142
0.5	60479	0.039144

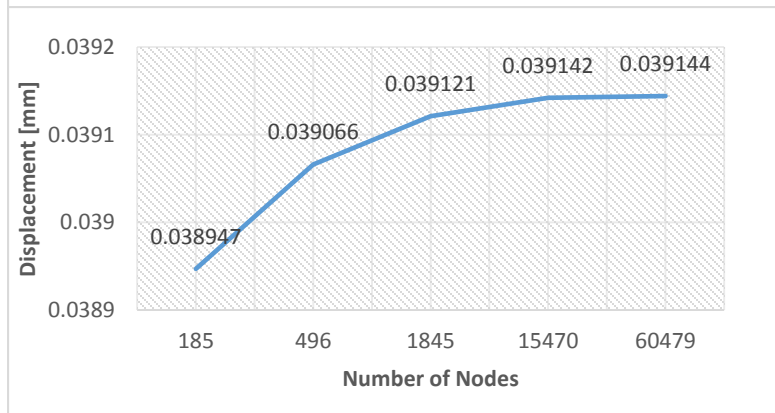
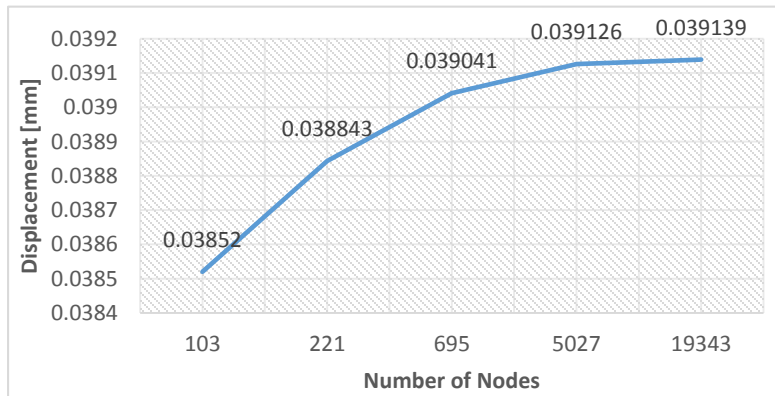

Here, we can observe a different phenomenon than the one we saw before. In this case as the Element Size decreases, the Number of Nodes increases, and as a result the Maximum Displacement also increases.

Taking a closer look at the Displacement results, someone can see that the differences are getting smaller, therefore convergent to some precise value.

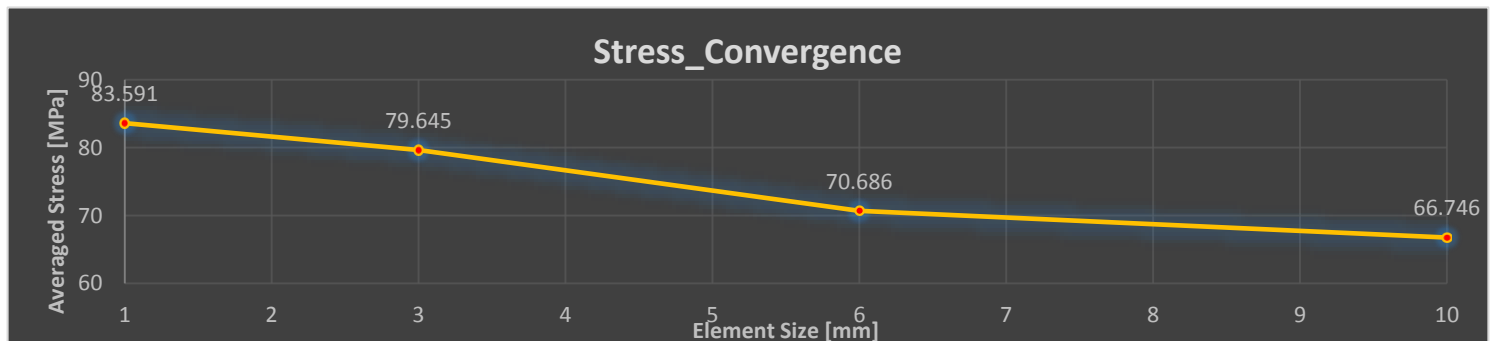

### 3.11 Stress Concentration

If we want to see how the stress concentrates in a specific area, we will need to create a path and then we will investigate the stresses along that path. Path command is also useful to make finer mesh in that specific area.

A path can be defined by two points, or an edge. Coordinates of the points can be either picked from the model or typed in the Details View.

Any result objects can scope on a path. After solving, a result vs path data table along with a graph will be generated.

When a path is short enough, it essentially becomes a single point. It is useful when you want to investigate the results of a point.

① Highlight Model/ Construction Geometry.

② Highlight Construction Geometry/ Path.

③ Select this vertex. You may need to turn on Selection Filter: Vertex.

④ Click Apply, do the same for the other point of

⑤ Insert another Normal Stress, and in the Detail View, select "Path" for both Scoping Method and Path.

Details of "Path"	
Definition	
Path Type	Two Points
Path Coordinate System	Global Coordinate System
Number of Sampling Points	47,
Suppressed	No
Start	
Coordinate System	Global Coordinate System
Start X Coordinate	157,5 mm
Start Y Coordinate	25, mm
Location	Click to Change
End	
Coordinate System	Global Coordinate System
End X Coordinate	0, mm
End Y Coordinate	0, mm
Location	Apply Cancel

Details of "Normal Stress 2"	
Scope	
Scoping Method	Path
Path	Path
Geometry	All Bodies
Definition	
Type	Normal Stress
Orientation	Y Axis

*So far, whenever we added a solution, in the solution branch, or we changed something in the mesh, afterwards to check the results we were using Solve option to do so.*

*We only did that, because it was faster and easier for us.*

*When you choose "Solve" to start the computation, it automatically runs all the Solution Information that we have added in Solution branch, even when some of those are already been computed. So far our computation were not so complicated and the resolving was fast.*

*Imagine what will happen when you have a computation that could last over a week, a modification in the mesh would be a huge time consumer.*

*There is a way to compute only the concepts that are not already computed, check the figures on the left.*

**Summarizing:** *You have to solve the computational model again.*

*But when you add more result outputs, like Normal Stresses, Equivalent Strain, etc., you need to update the results by "Evaluate All Results" option.*

**Solution (B6)**

- Solution Information
- Directional Deformation
- Normal Stress
- Normal Stress 2, Unaveraged
- Structural Error
- Normal Stress 2

Insert

- Evaluate All Results
- Suppress
- Duplicate
- Duplicate Without Results
- Copy
- Cut
- Clear Generated Data
- Delete
- Rename (F2)
- Rename Based on Definition
- Group
- Group Similar Objects

⑥ Right-click on Normal Stress 2 (the one containing Path), and Evaluate All Results.

3.11.1 View the Path Results

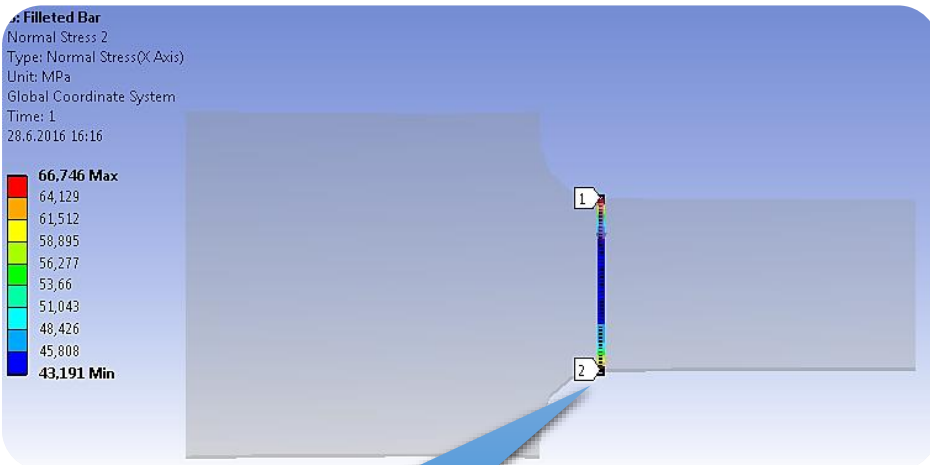

① With "Normal Stress" highlighted, Mechanical GUI should look like this.

② Since the results scope on the path, only the path has stress values, indicated by the colors.

③ Stress values are listed as a function of path length.

Tabular Data		
	Length [mm]	Value [MPa]
1	0,	66,435
2	1,0417	63,806
3	2,0833	61,249
4	3,125	58,762
5	4,1667	56,344
6	5,2083	53,994
7	6,25	51,708
8	7,2917	49,487
9	8,3333	47,328
10	9,375	46,444
11	10,417	46,146
12	11,458	45,842
13	12,5	45,533
14	13,542	45,219
15	14,583	44,9
16	15,625	44,575
17	16,667	44,246
18	17,708	43,912
19	18,75	43,573
20	19,792	43,229

④ This is the curve of Stress Vs Length.

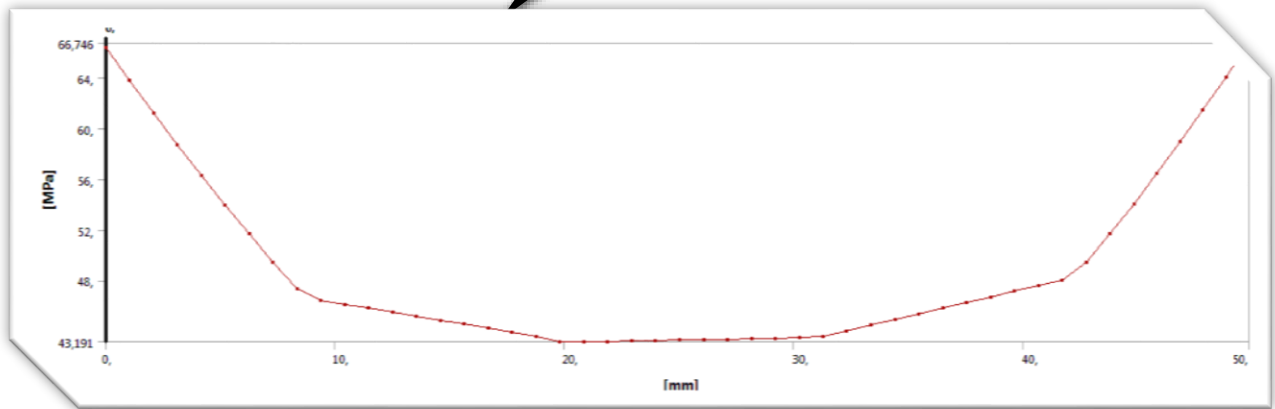

## CHAPTER\_IV: SHAFT

## 4.1 Problem Description

Reference --> University of Wisconsin-Madison, Department of Engineering Physics

**Axisymmetric Analysis** - The axisymmetric problem deals with the analysis of structures of revolution under axisymmetric loading. A structure of revolution is generated by a generating cross section that rotates 360° about an axis of revolution, as illustrated in Figures below. Such structures are said to be rotationally symmetric.

A structure of revolution by itself does not necessarily define an axisymmetric problem. It is also necessary that the loading, as well as the support boundary conditions, be rotationally symmetric.

Axisymmetric elements are 2D elements that can be used to model axisymmetric geometries with axisymmetric load. In simpler words, we are converting a 3D Geometry to a 2D Geometry making the model smaller, therefore faster execution and faster post processing.

We only model the cross section, and ANSYS accounts for the fact that it is really a 3D, axisymmetric structure.

Examples before beginning our task

Cases:

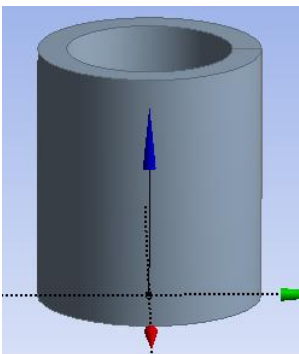

Cylinder with hole.

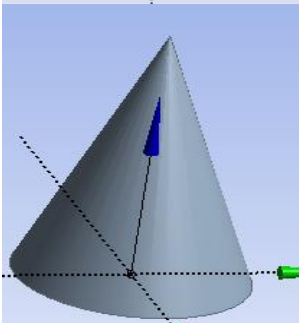

Pyramid.

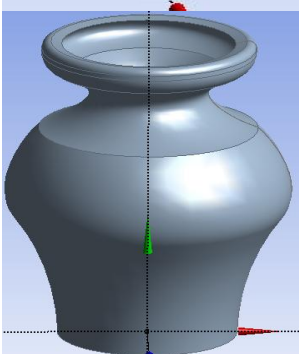

Vase.

Surface needed:

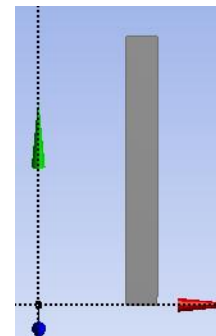

# In ANSYS, axisymmetric models must be drawn in XY Plane.

# The X direction is the radial direction.

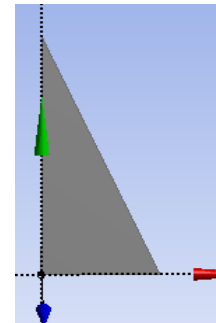

# The 2D model will be rotated about the Y axis (always about  $x=0$ ).

# Nothing in your model should be in the region  $X < 0$ .

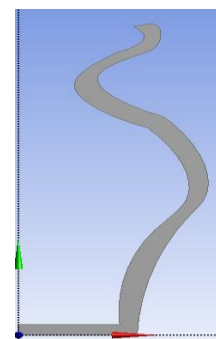

# In post processing  $\sigma_x$  will be the radial stress,  $\sigma_y$  will be the axial stress, and  $\sigma_z$  will be the "hoop" stress.

## Shaft Description

In this chapter we consider the finite element discretization of axisymmetric solids. We were given a Steel Shaft with dimensions which are given below. Purpose of this chapter is to evaluate stress concentration factor of the shaft notch, compare the result with the experimental data and fully understand the concept of Axi-symmetry and its possibilities.

## # Inputs →

**Material**

Structural Steel: Young's Modulus = 200 GPa;

Poisson's Ratio = 0.3;

**Dimensions**

$h = 150 \text{ mm};$        $R = 5 \text{ mm};$        $l = 75 \text{ mm};$   
 $P = 50 \text{ MPa};$        $d = 15 \text{ mm};$

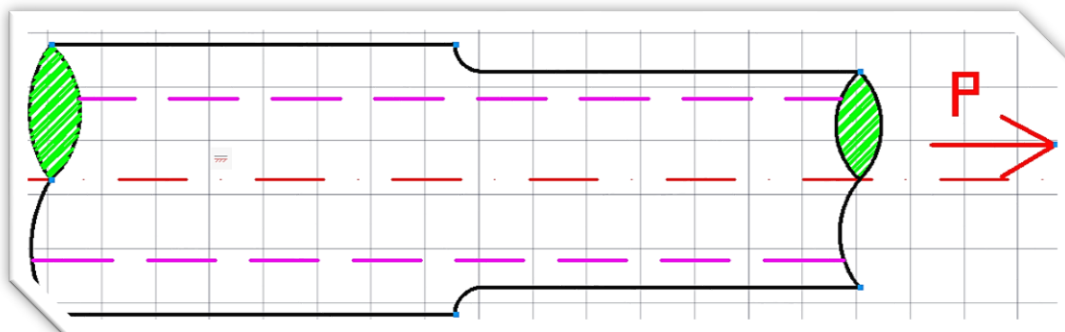
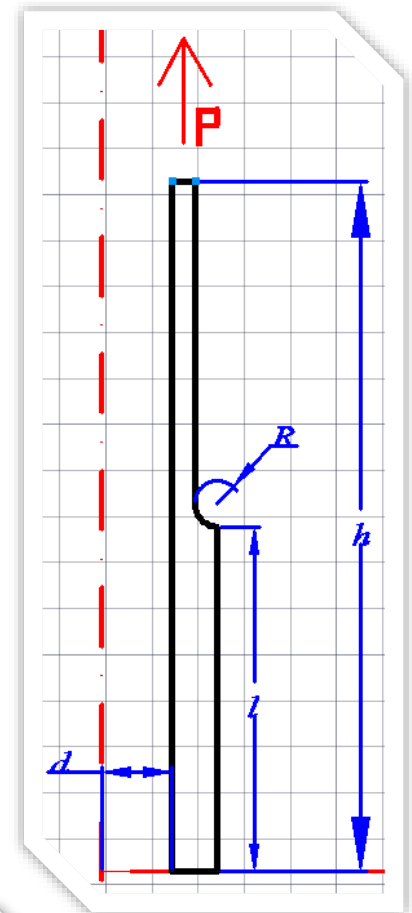
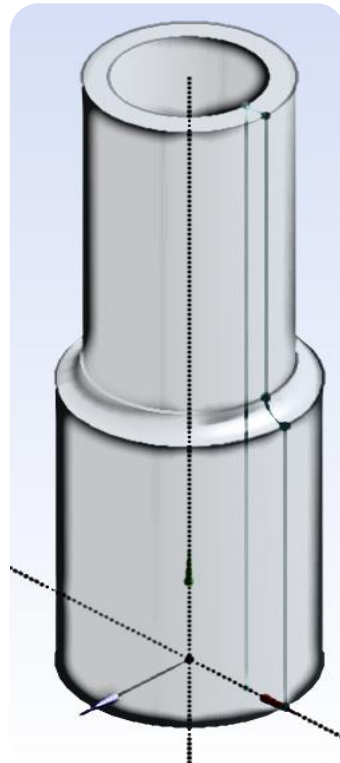

### 4.2 Start-Up

Open ANSYS Workbench, create a Static Structural system, and make sure that you saved your case study before moving forward. Next step is opening Engineering Data tab, to check if the material properties are correct. After doing, that highlight Geometry and change the Analysis Type on your right, from 3D to 2D. Double-click Geometry to start sketching.

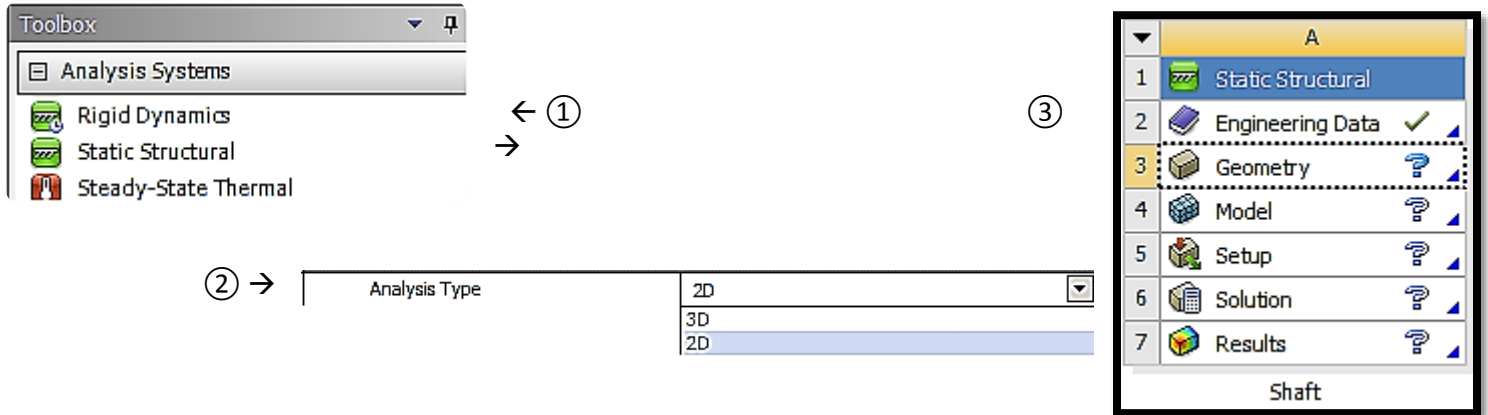

### 4.3 Create Body

➤ After DesignModeler opens, get to the Units tab, and select Millimeter. Highlight XYPlane and start sketching.

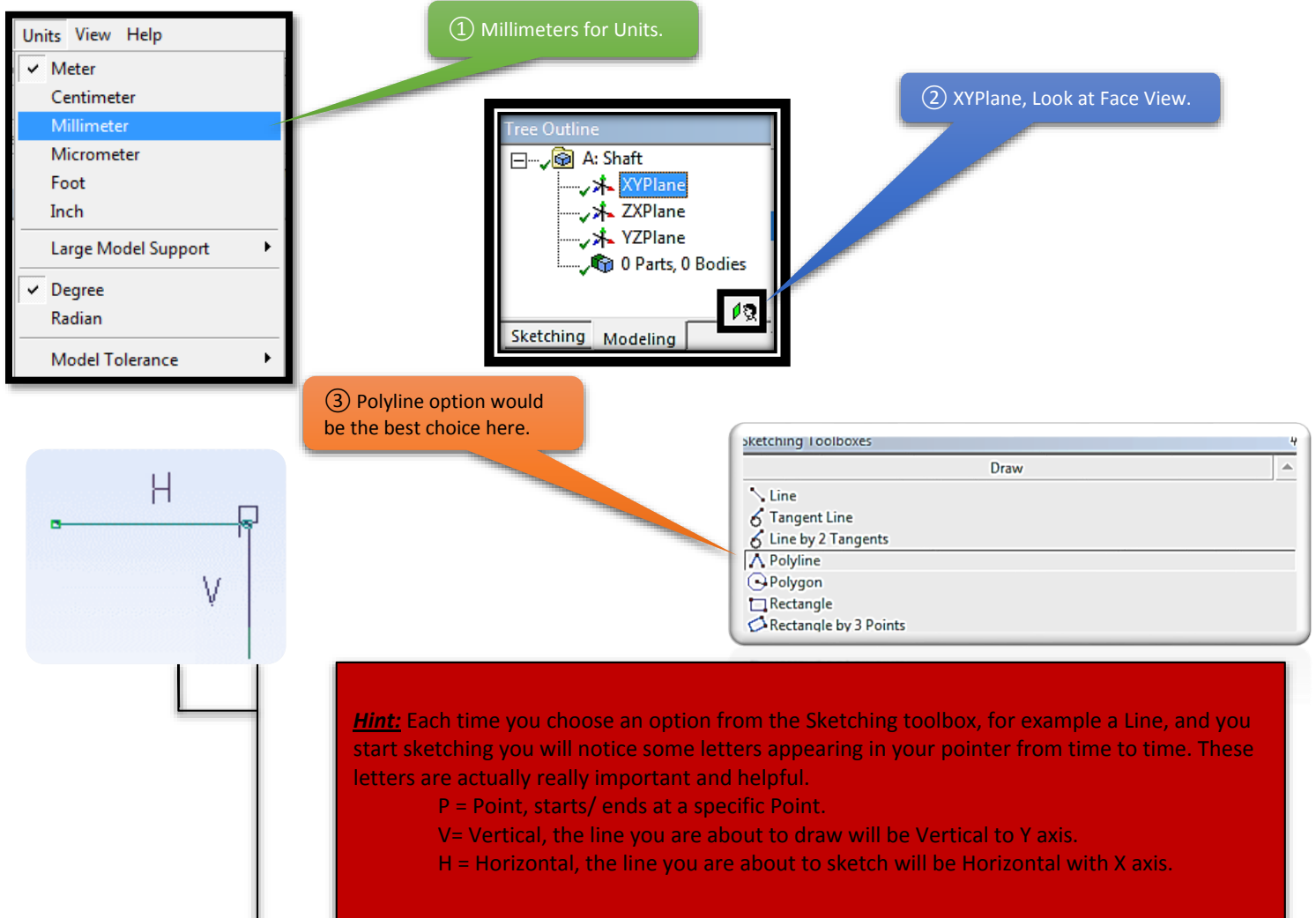

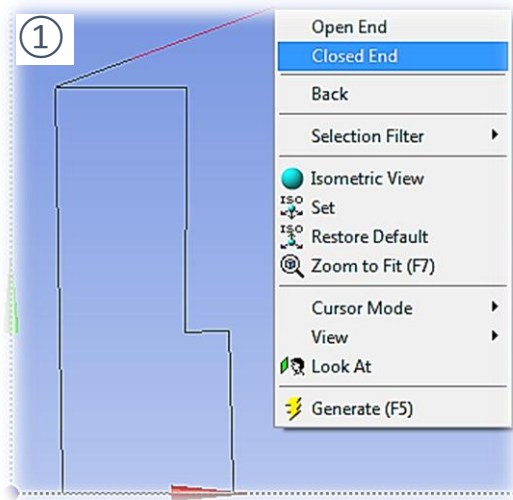

① → Draw down this sketch, and try to take advantage of the pointer letters we mentioned above. Closed End is necessary at the end point.

② → In this figure you can see your end sketch if you use the point letters correctly. Adjust the dimension similar like on this figure.

③ → Dimension Box, input the following dimensions to complete our Sketch.

④ → Go to Modify, Fillet and place it at the point where we want our shaft to have the radius.

⑤ → Dimensions, Radius and place it likewise the figure, also change the radius input to 5mm. A Warning window will pop-up, telling you that some edges or radius will be deleted, you can ignore that warning window.

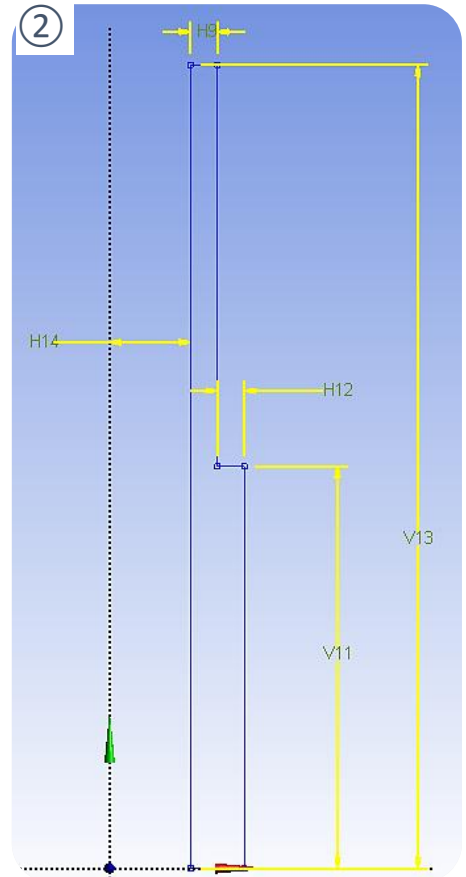

③

Dimensions: 5	
<input type="checkbox"/> H12	5 mm
<input type="checkbox"/> H14	15 mm
<input type="checkbox"/> H9	5 mm
<input type="checkbox"/> V11	75 mm
<input type="checkbox"/> V13	150 mm

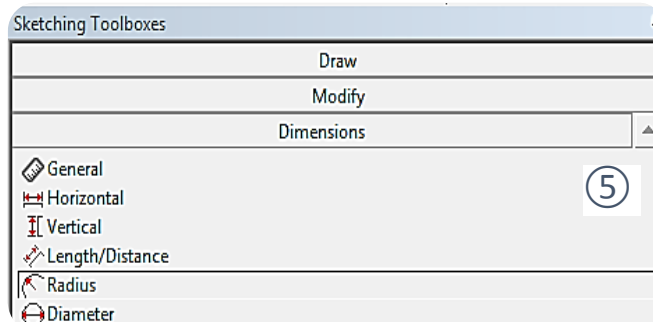
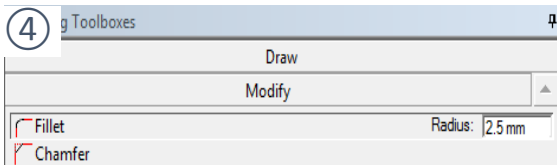

4.3.1 Getting back to the Modeling

① Highlight Sketch1, and go to Concept/Surfaces From Sketches to create our surface.

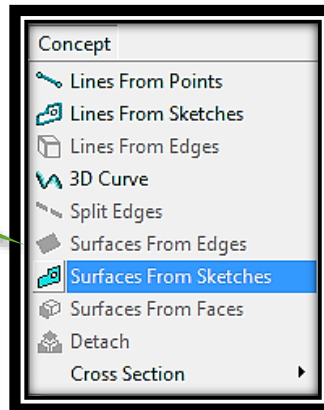

② Details View of SurfaceSk1 should be the same like here.

Details View	
Details of SurfaceSk1	
Surface From Sketches	SurfaceSk1
Base Objects	1 Sketch
Operation	Add Material
Orient With Plane Normal?	Yes
Thickness (>=0)	0 mm

④ Your revolved model should look like this.

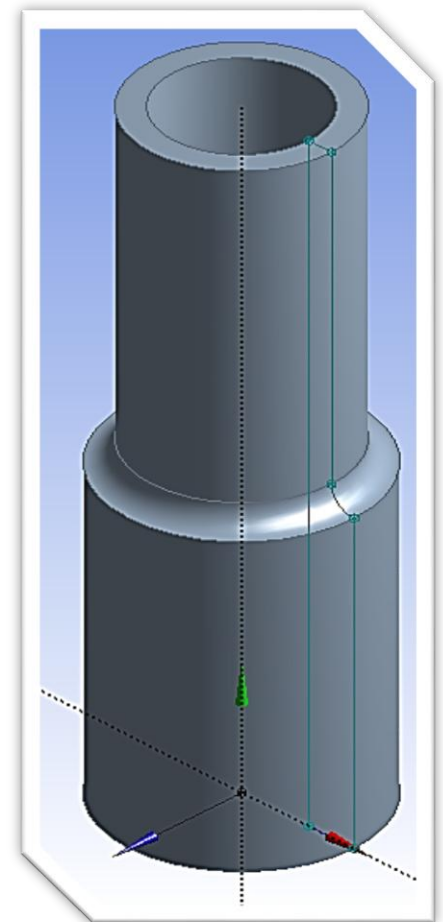

⑤ Details View of Revolve option.

Details View	
Details of Revolve1	
Revolve	Revolve1
Geometry	Sketch1
Axis	Plane Normal
Operation	Add Material
Direction	Normal
<input type="checkbox"/> FD1, Angle (>0)	360 °
As Thin/Surface?	No
Merge Topology?	Yes
Geometry Selection: 1	
Sketch	Sketch1

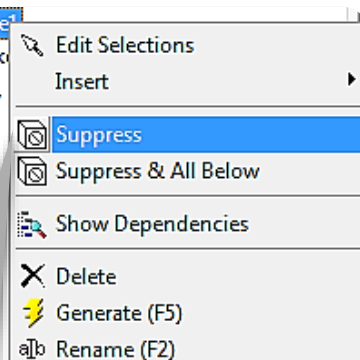

③ If you are still curious how can a surface create a whole 3D body, you can use the Revolve option.

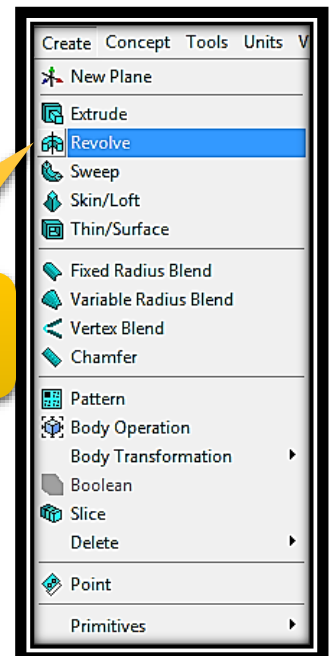

⑥ Revolve option was only for demonstration. Now you will have to Suppress it.

### 4.4 Set Up Mesh Controls

After finishing your sketch, close DesignModeler and open up Mechanical. First thing we need to adjust before start dealing with the Analysis, is to change Geometry's behavior.

① Highlight Geometry, move to Details of "Geometry" and change 2D Behavior to "Axisymmetric".

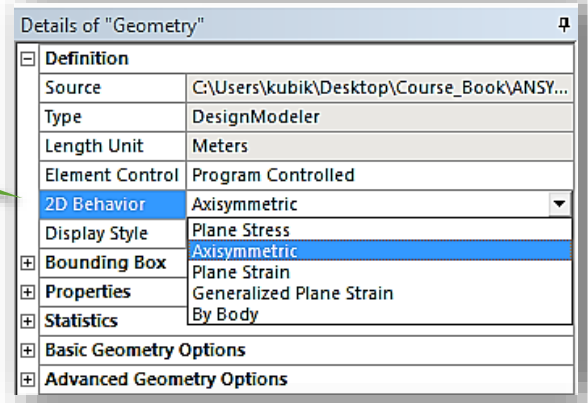

② Highlight Mesh, and choose "Sizing" from Mesh Control drop down list.



③ Change Element Size and leave rest as Default.

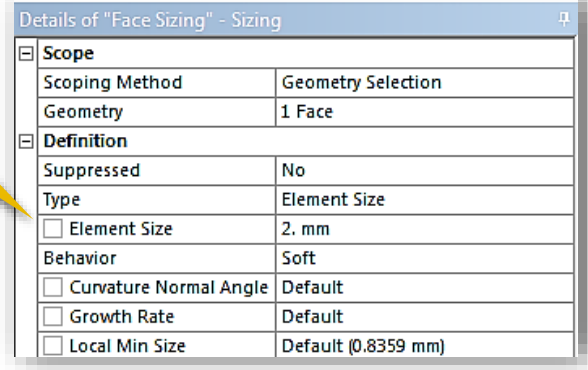

④ Highlight Mesh, and choose "Refinement" from Mesh Control drop down list, in order to create a finer mesh to a specific point.

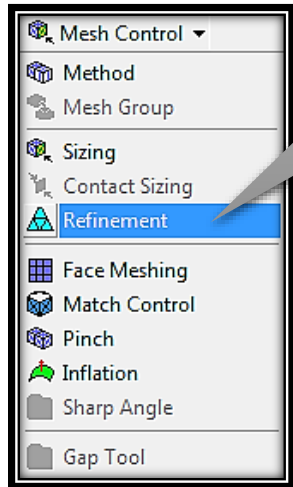

⑤ Details of Refinement, for Geometry choose #7.

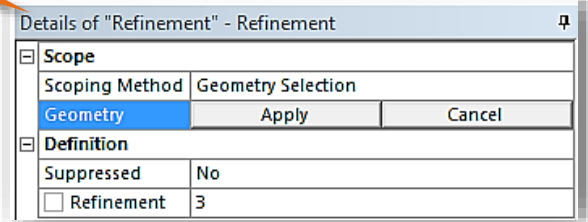

⑥ Activate this option, to be able to select the radius edge.

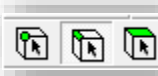

⑦ Finer mesh, in a specific radius edge.

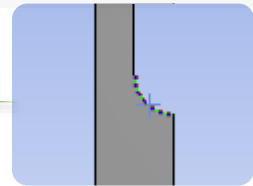

⑨ My Mesh. You can see how much finer the mesh is in the radius part.

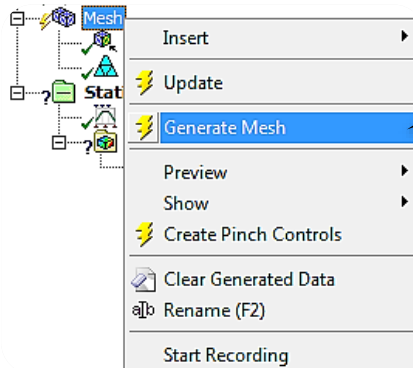

⑧ Highlight Mesh, right-click on it and "Generate Mesh".

### 4.5 Set Up Supports, Loads

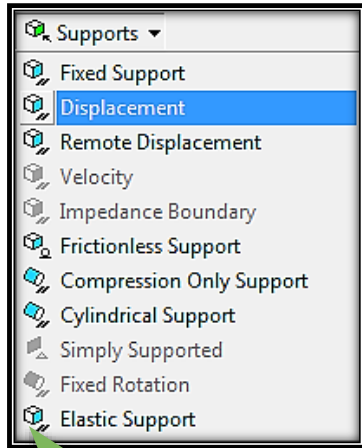

① Select Displacement Support, because we are interested only the  $U_y = 0$ .

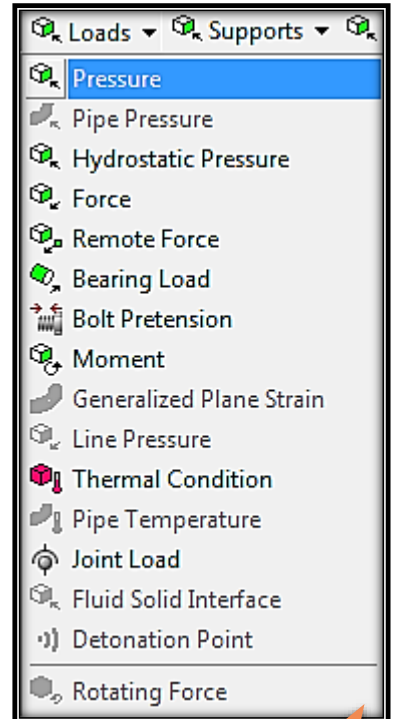
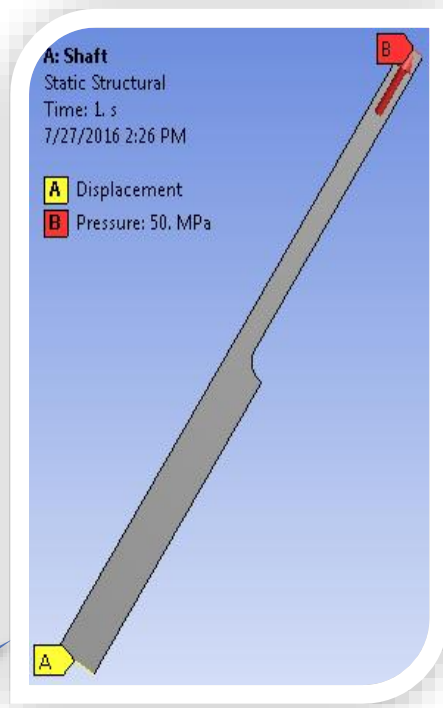

② Pressure of 50MPa, applied to Y direction.

③ Supports and Loads View.

Details of "Displacement"	
<b>Scope</b>	
Scoping Method	Geometry Selection
Geometry	1 Edge
<b>Definition</b>	
Type	Displacement
Define By	Components
Coordinate System	Global Coordinate System
X Component	Free
<b>Y Component</b>	0. mm (ramped)
Suppressed	No

Details of "Pressure"	
<b>Scope</b>	
Scoping Method	Geometry Selection
Geometry	1 Edge
<b>Definition</b>	
ID (Beta)	63
Type	Pressure
Define By	Components
Coordinate System	Global Coordinate System
<input type="checkbox"/> X Component	0. MPa (ramped)
<input checked="" type="checkbox"/> Y Component	50. MPa (ramped)
Suppressed	No

### 4.6 Set Up Solution Outcome Branch

① The steps are the same here, choose Deformation and Stress evaluation results from the drop down lists. I used Total Deformation, Max. Principal and Normal Stress.

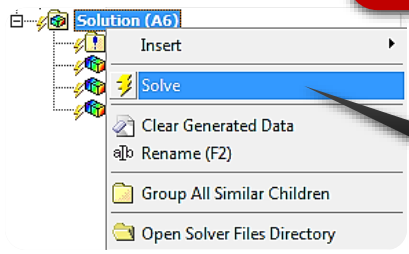
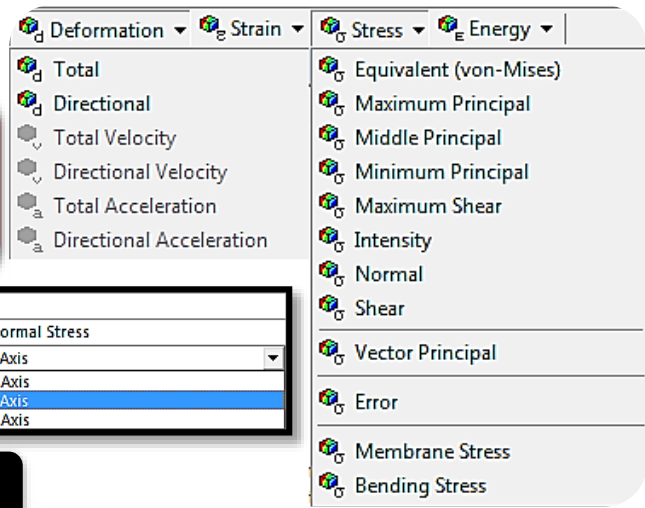

Definition	
Type	Normal Stress
Orientation	Y Axis
	X Axis
	Y Axis
	Z Axis

② Highlight Solution, right-click and choose Solve.

### 4.7 View the Results

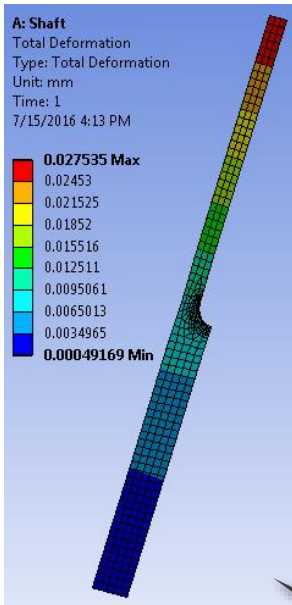

Total Deformation.

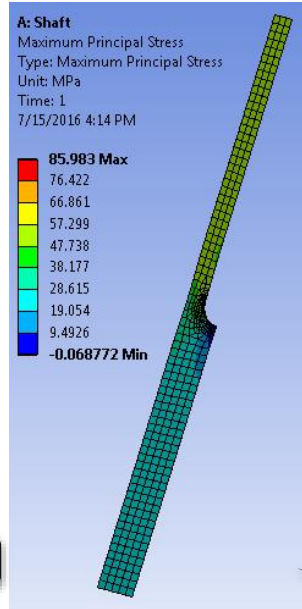

Principal Stress.

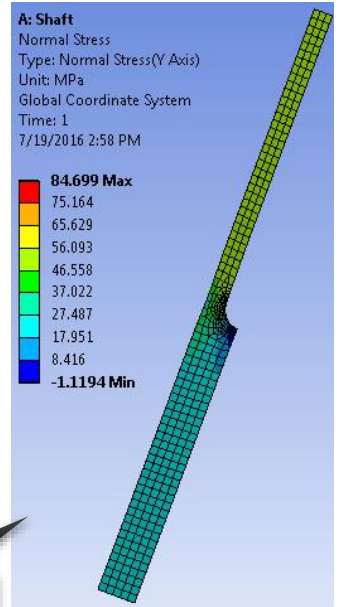

Normal Stress.

## 4.7.1 Activating 3D View

To help you understand the ideology of Axisymmetry, I will have to show you how to activate a couple of options to make a better visualization output of the results.

① You will need to get back to ANSYS Workbench, you don't need to close Mechanical window. Go to Tools → Options.

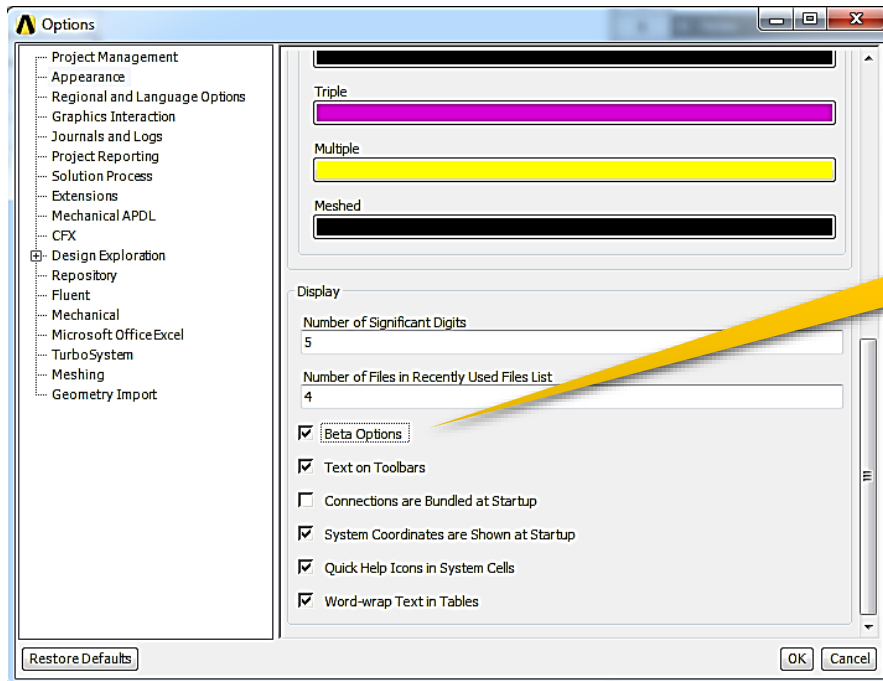
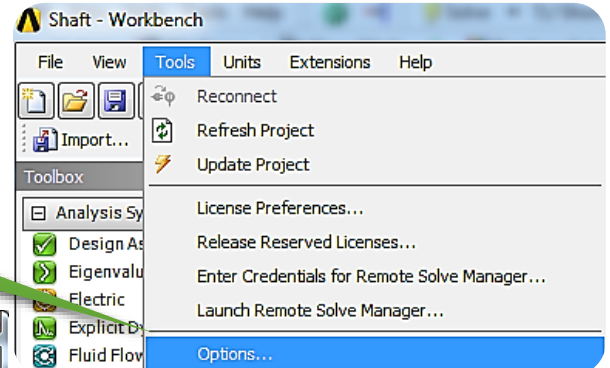

② In the Appearance tab, tick Beta Options, and then click OK.

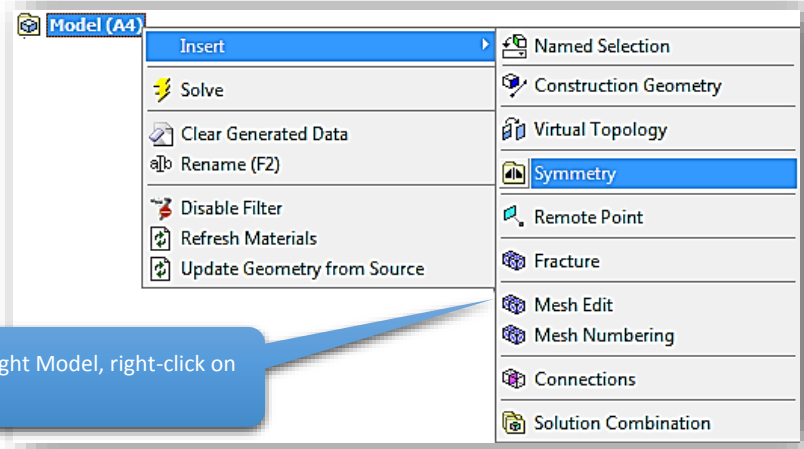

③ Get back to Mechanical, highlight Model, right-click on it/ Insert/ Symmetry.

Details of "Symmetry"	
[-] Graphical Expansion 1 (Beta)	
Num Repeat	0
Type	Cartesian
Method	Cartesian
$\Delta X$	Polar
$\Delta Y$	2D AxiSymmetric
$\Delta Z$	0. mm
Coordinate System	Global Coordinate System
[-] Graphical Expansion 2 (Beta)	
Num Repeat	0
Type	Cartesian
Method	Full
$\Delta X$	0. mm
$\Delta Y$	0. mm
$\Delta Z$	0. mm
Coordinate System	Global Coordinate System
[-] Graphical Expansion 3 (Beta)	
Num Repeat	0
Type	Cartesian
Method	Full
$\Delta X$	0. mm
$\Delta Y$	0. mm
$\Delta Z$	0. mm
Coordinate System	Global Coordinate System

④ Details of "Symmetry" will appear, change the Type to "2D AxiSymmetric".

Details of "Symmetry"	
[-] Graphical Expansion 1 (Beta)	
Num Repeat	15
Type	2D AxiSymmetric
$\Delta\theta$	10. °
Coordinate System	Global Coordinate System

⑤ When you choose "2D AxiSymmetric", the Details of "Symmetry" will turn into this window. Adjust the Parameters according to the figure.

⑥ This is the Graphic Result of the Symmetry Option.

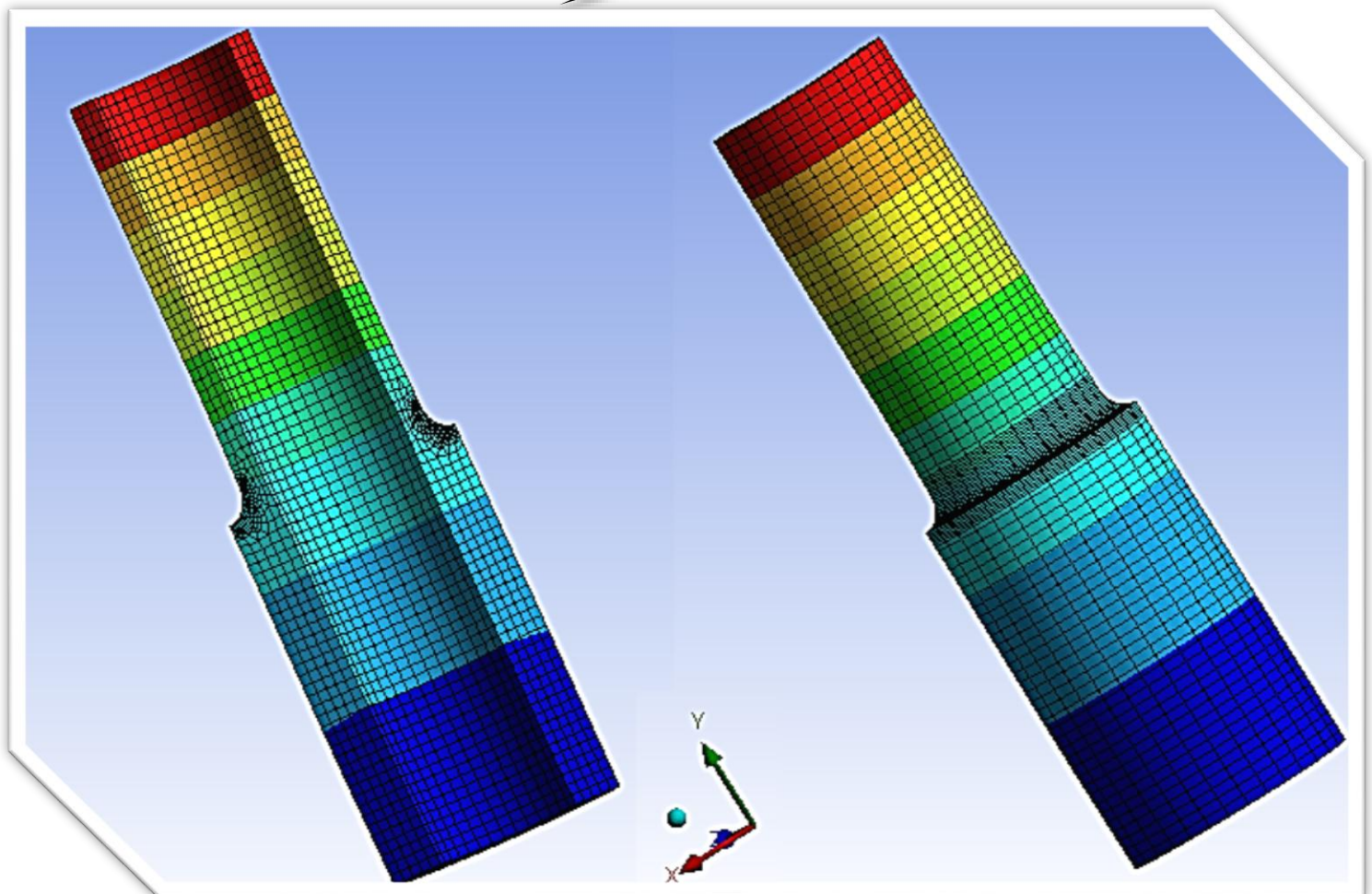

## 4.9 Stress Concentration Factor

A stress concentration is a location in an object where stress is concentrated. An object is strongest when force is evenly distributed over its area, e.g. caused by a crack, results in a localized increase in stress. A material fail, via a propagating crack, when a concentrated stress exceeds the material's theoretical cohesive strength. The real fracture strength of a material is always lower than the theoretical value because most materials contain small cracks or contaminants that concentrate stress.

The stress concentrators are geometrical irregularities that cause an increase in the average effort that should be present in regions near these discontinuities, the relationship between the maximum stress that occurs and the average effort that should occur is defined as stress concentration factor; which is determined by experimental or analytical methods and presented in graphical form for ease interpretation.

The stress concentration factor for a tube in tension with fillet, our case, can be determined as the relation of the maximum normal stress in the discontinuity and the nominal stress, and is obtained through the equation:

Reference -> Pickey W.: Peterson's Stress Concentration Factors.

$$K_t = \frac{\sigma_{\max}}{\sigma_{\text{nom}}} \quad \textcircled{1} \quad (d_i/h + d_i/t) > 28 \quad \textcircled{3}$$

$$\sigma_{\text{nom}} = \frac{P}{\pi h (d_i + h)} \quad \textcircled{2}$$

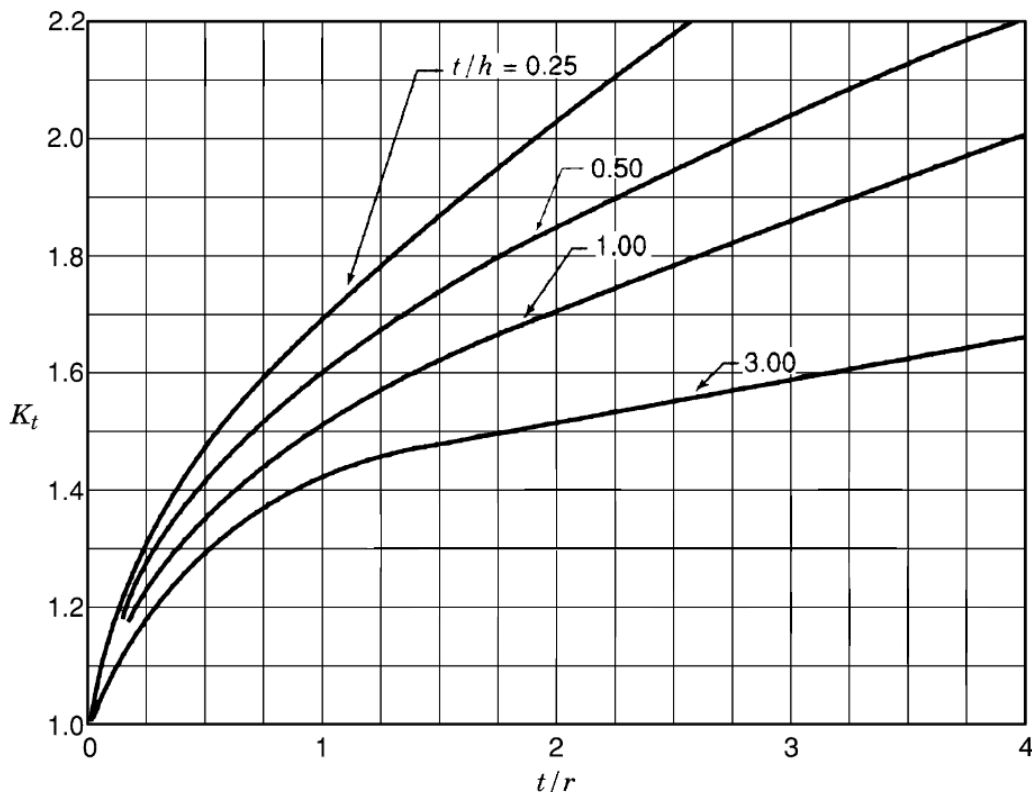
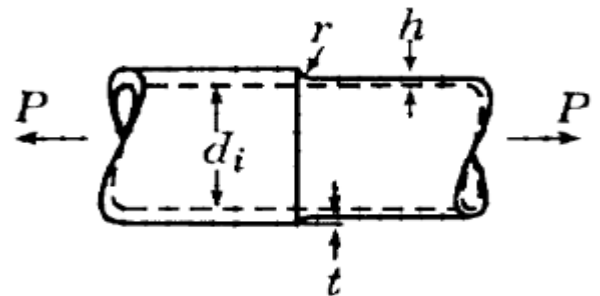

**Chart** Stress concentration factors  $K_t$  for a tube in tension with fillet (Lee and Ades 1956; ESDU 1981).

## 4.9.1 Hand Calculations VS Computational Calculations of Stress Concentration

## Hand Calculations

As we can see in the graph, there are 2 parameters that are taken into consideration to acquire stress concentration factor. First parameter would be to determine which line we need to choose, to accomplish that we have to solve the equation  $t/h$  with our given values. Second parameter would be to acquire the correct output for the X axis, solving the equation  $t/r$ .

According to the graph, my results are:

- $t/r = 5/5 = 1$
- $t/h = 5/5 = 1$



- $K_t \approx 1.52$

## Computational Calculations

To acquire the Stress Concentration Factor for the computational calculations we are going to need Max. Normal Stress (Y Axis) and Nominal Stress, which in our case equals to 50MPa because of Pressure.

We do not need to calculate the Max. Normal Stress (Y Axis) as ANSYS Workbench can do it for us.

Highlight Normal Stress from the Solution branch. Those 3 options will appear at the Mechanical GUI, "Max." and "Min." Buttons will show you where the maximum and the minimum output value is located at your Geometry. "123 Probe" button will give you permission to check the output result in any point throughout your geometry.

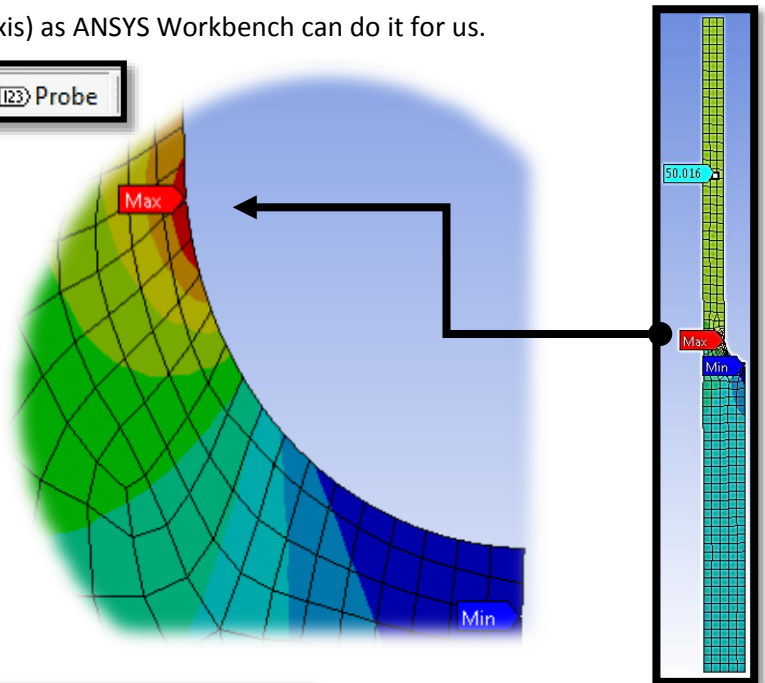

According to the computational results: ②

- $K_t = 84.699 \text{ MPa} / 50 \text{ MPa}$



- $K_t \approx 1.69$

## Solving the Equation

- $(d_i/h + d_i/t) > 28 \Rightarrow (30/5 + 30/5) > 28 \Rightarrow 12 > 28$  ③

**Conclusion:** As we can see the results between Hand and Computational Calculations are almost the same. The difference of 11% is probably because of the geometry. Geometry proportion does not meet the criterion for the experimental data in the Stress Concentration Factor diagram, [Eq. ③]. The Geometry proportion coefficient should be greater than 28.

### 4.10 Redefining Mesh

At this point we come across with an opportunity, to help you understand the concepts and the possibilities of Mesh and its options. To be more specific, we will change our element and node parameters (make it smaller, and finer), to check what happens to the Stress Concentration Factor. We are aiming to reduce the difference to a minimum value.

① Open up Mechanical from the Static Structural System.

② When Mechanical GUI loads, open Mesh branch, highlight Face Sizing, and go to the Details of "Face Sizing".

③ We are interested in making the Global Mesh two times finer, meaning that we are going to change the Element Size down to 0.5 mm.

④ The Refinement Mesh option ranges from 1 to 3 (minimum to maximum). Refinement splits the edge of the elements in the "initial" mesh in half. Input value 1 WHY?

⑤ After adjusting our new input values, hit Solve.

⑥ Highlighting the Normal Stress tab, you are able to visualize your results. Here are my own results.

⑦ We can see that the Max. Normal Stress value is smaller than before. That is due to the new Mesh parameters.

⑧ Calculating the new Stress Concentration Factor.

② →  $K_t = 84.617 \text{ MPa} / 50 \text{ MPa}$  →  $K_t \approx 1.68$

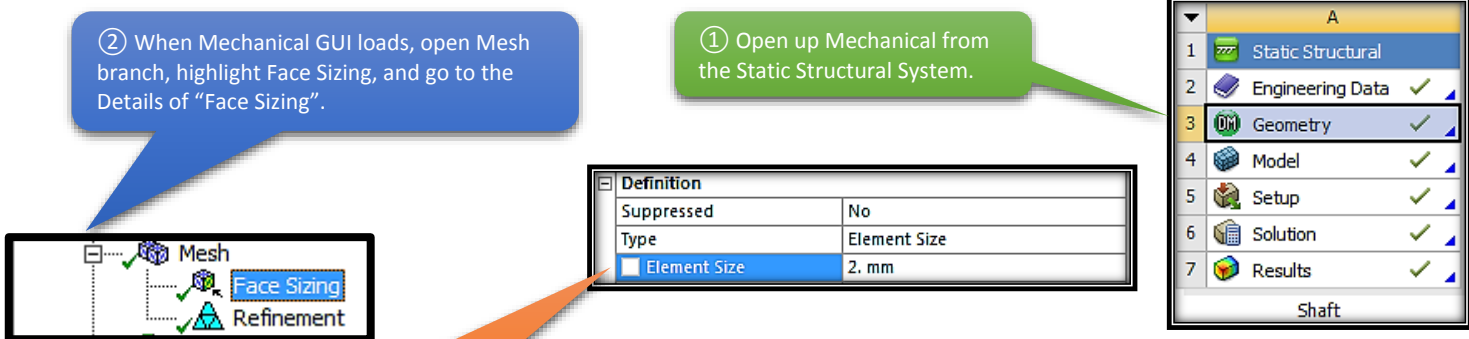

Definition	
Suppressed	No
Type	Element Size
Element Size	2. mm

Definition	
Suppressed	No
Refinement	1

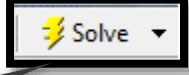
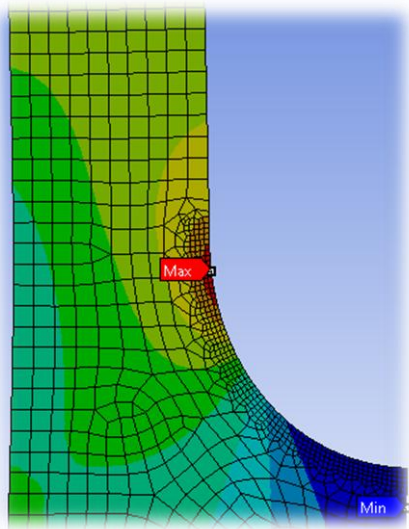
A: Shaft	
Normal Stress	
Type: Normal Stress(Y Axis)	
Unit: MPa	
Global Coordinate System	
Time: 1	
7/22/2016 1:07 PM	
84.358 Max	
74.861	
65.363	
55.866	
46.369	
36.871	
27.374	
17.876	
8.3789	
-1.1185 Min	

➤ We can see that, we may got a difference in the Stress Concentration Factor but it is negligible.

---

 CHAPTER\_V: LEVEL OF GEOMETRY
 

---

## 5.1 Problem Description

**Beam Element** - A beam element is a slender structural member that offers resistance to forces and bending under applied loads. A beam element differs from a truss element in that a beam resists moments (twisting and bending) at the connections.

These three node elements are formulated in three-dimensional space. The first two nodes (I-node and J-node) are specified by the element geometry. The third node (K-node) is used to orient each beam element in 3-D space (see Figure 1). A maximum of three translational degrees-of-freedom and three rotational degrees-of-freedom are defined for beam elements (see Figure 2). Three orthogonal forces (one axial and two shear) and three orthogonal moments (one torsion and two bending) are calculated at each end of each element. Optionally, the maximum normal stresses produced by combined axial and bending loads are calculated. Uniform inertia loads in three directions, fixed-end forces, and intermediate loads are the basic element based loadings.

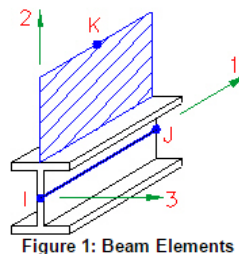

Figure 1: Beam Elements

Reference --> Autodesk Network Article.

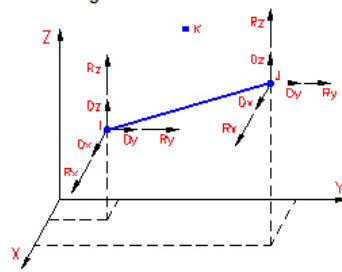

Figure 2: Beam Element Degrees-of-Freedom

The basic guidelines for when to use a beam element are:

- The length of the element is much greater than the width or depth.
- The element has constant cross-sectional properties.
- The element must be able to transfer moments.
- The element must be able to handle a load distributed across its length.

**Solid Element** – Solid elements are three-dimensional finite elements that can model solid bodies and structures without any *a priori* geometric simplification.

Finite element models of this type have the advantage of directness. Geometric, constitutive and loading assumptions required to effect dimensionality reduction, for example to planar or axisymmetric behavior, are avoided. Boundary conditions on both forces and displacements can be more realistically treated. Another attractive feature is that the finite element mesh visually looks like the physical system.

Summarizing, use of solid elements should be restricted to problem and analysis stages, such as verification, where the generality and flexibility of full 3D models is warranted. They should be avoided during design stages. Furthermore they should also be avoided in thin-wall structures such as aerospace shells, since solid elements tend to perform poorly because of locking problems.

**Shell Element** – Shell elements are 4- to 8-node isoparametric quadrilaterals or 3- to 6-node triangular elements in any 3-D orientation. The 4-node elements require a much finer mesh than the 8-node elements to give convergent displacements and stresses in models involving out-of-plane bending. Figure 1 shows some typical shell elements.

The General and Co-rotational shell element is formulated based on works by Ahmad, Iron and Zienkiewicz and later refined by Bathe and Balourchi. It can be applied to model both thick and thin shell problems. Also, the geometry of a doubly curved shell with variable thickness can be accurately described using this shell element.

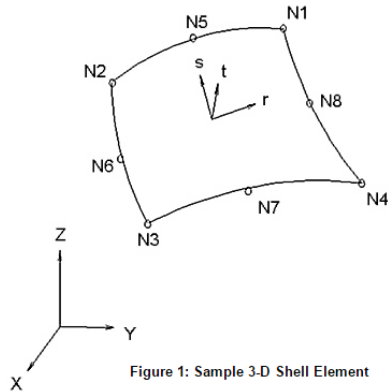

Figure 1: Sample 3-D Shell Element

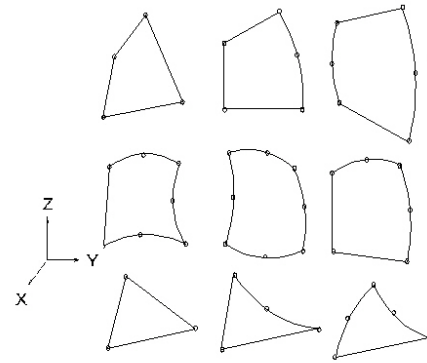

Figure 2: Typical Shell Elements

The Thin shell element is based on thin plate theory. The bending behavior of the element is based on a discrete Kirchhoff approach to plate bending using Batoz's interpolation functions. This formulation satisfies the Kirchhoff constraints along the boundary and provides linear variation of curvature through the element. The membrane behavior of the element is based on the Allman triangle which is derived from the Linear Strain Triangular (LST) element. A general curved surface is approximated by this element as a set of facets formed by the planes defined by the three nodes of each element. For these reason a well-refined mesh is necessary.

The element geometry is described by the nodal point coordinates. Each shell element node has 5 degrees of freedom (DOF) - three translations and two rotations. The translational DOF are in the global Cartesian coordinate system. The rotations are about two orthogonal axes on the shell surface defined at each node. The rotational boundary condition restraints and applied moments also refer to this nodal rotational system. The two rotational axes (V1 and V2) are usually automatically determined by the processor and you do not have to specifically orient them.

### Car Chassis Description

To be able to make the comparison between beam, solid and surface elements we are going to need a geometry which is compatible with all 3 parameters. That is why we are going to use a part of a Car Chassis with dimensions and loads which are given below.

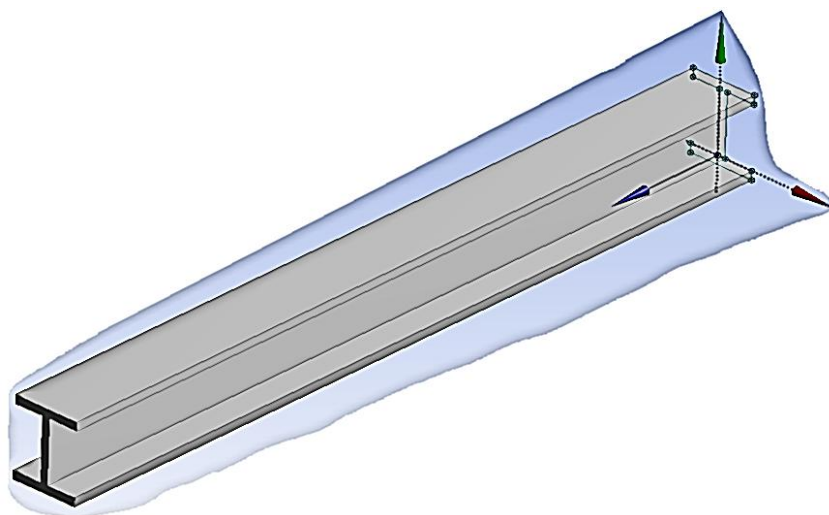

## # Inputs →

**Material**

Structural Steel: Young's Modulus = 200 GPa;  
Poisson's Ratio = 0.3;

**Dimensions**

$h = 115 \text{ mm};$                        $a = 12.5 \text{ mm};$   
 $l = 100 \text{ mm};$                        $m = 1200 \text{ mm};$   
 $d = 20 \text{ mm};$                          $P = 10 \text{ MPa};$

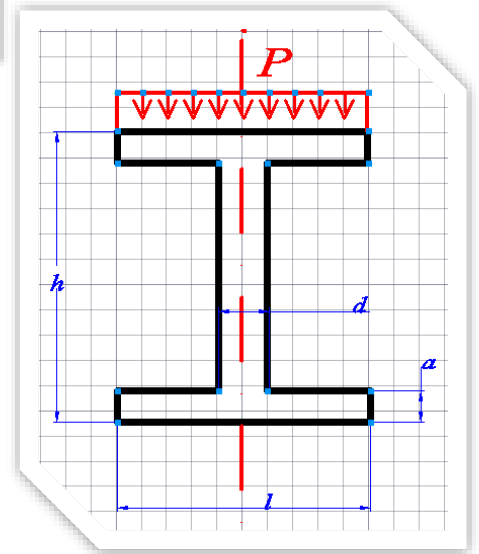
**Supports**

- Fixed Support at "A" and "B" point;
- Displacement Support with  $U_x=0$  and  $R_z=0$ , rest Degrees of Freedom are free;

In case of Symmetry in "O".

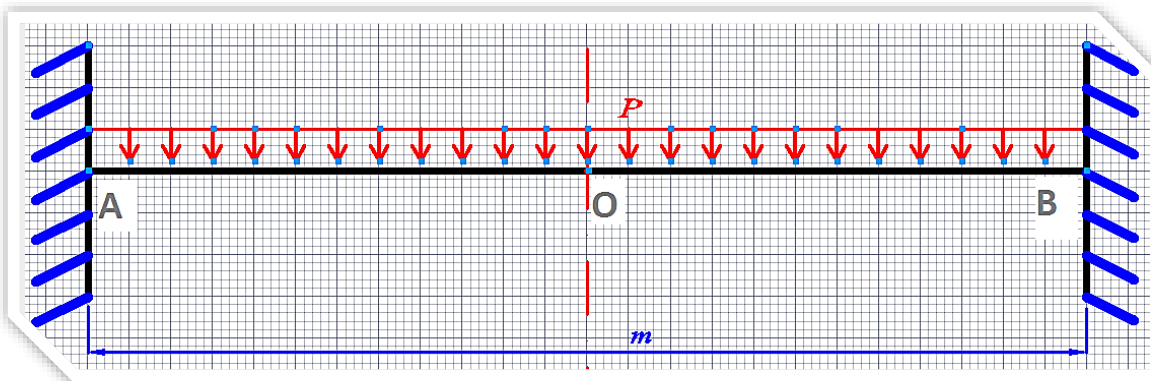

## i. Beam Elements

### 5.2.i Start Up

Once you opened up ANSYS Workbench, create a new Static Structural System and save your study case to a proper destination folder. Afterwards open the Engineering Data tab and make sure that the material properties match our data. Getting back now to the Project tab, we need to make an adjustment, since we are working with Beam Elements. For that reason, highlight Geometry from the Static Structural System and tick the box in the Basic Geometry Options tab, the one concerning the Line Bodies. Double click on Geometry to start sketching.

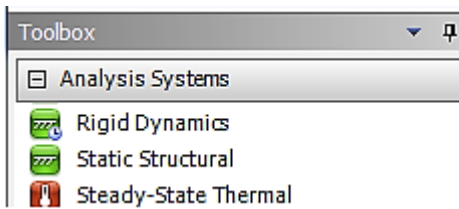

← ①

② →

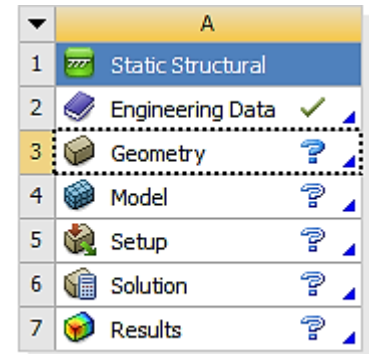

③ →

Basic Geometry Options		
12	Solid Bodies	<input checked="" type="checkbox"/>
13	Surface Bodies	<input checked="" type="checkbox"/>
14	Line Bodies	<input type="checkbox"/>
15	Parameters	<input checked="" type="checkbox"/>

Shaft

### 5.3.i Create Body

When the DesignModeler loads, make sure to change the Units type to Millimeter and move to the Sketching tab after highlighting the XYPlane of the Chassis.

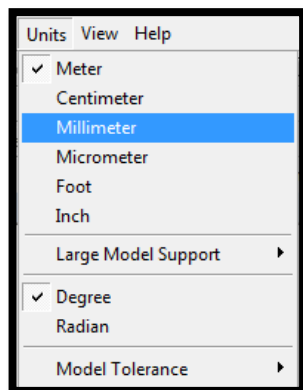

① Millimeters for Units.

② XYPlane, Look at Face View.

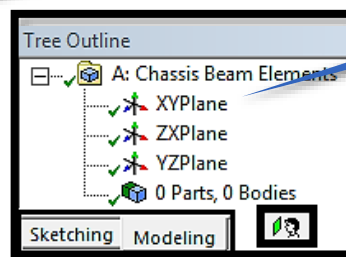

As you noticed in the Problem Description paragraph, our model is symmetric, meaning that we got the option here to sketch only half of the geometries body without having differences at the end results. So, getting back to the sketching part, we will need firstly to create just a single line and then it's Cross-Section.

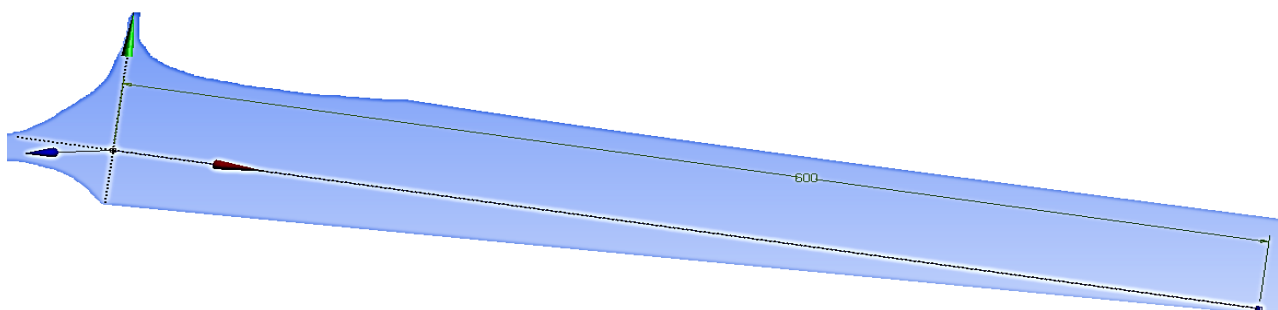

➤ After creating the geometry, in our case the single Line, head back to Modelling tab.

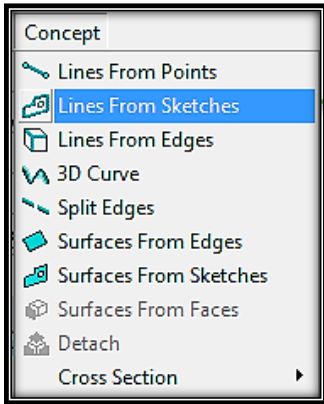

① Highlight Sketch1, and go to Concept/ Lines From Sketches. Then click Apply on the Base Objects.

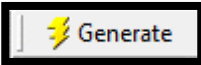

② When you click on Generate, your Tree Outline should look like the figure on the right.

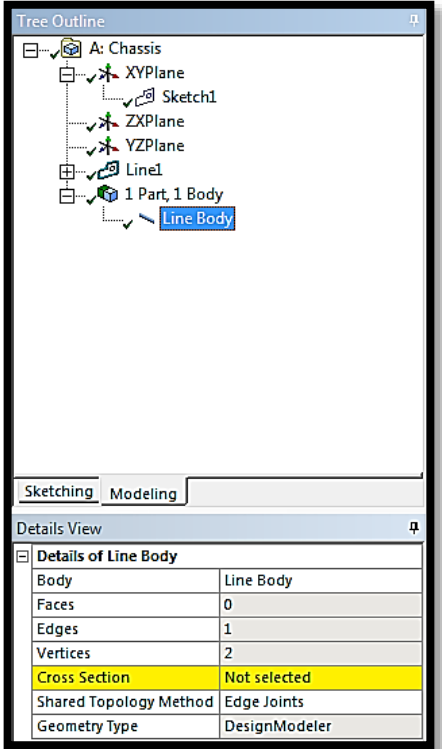

③ Next step is to assign the Cross-Section. Go to Concept/ Cross Section/ I Section.

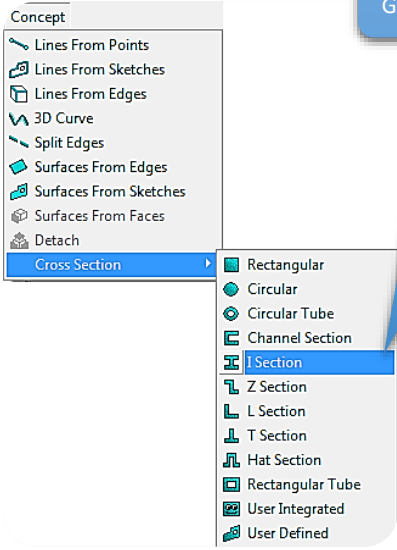

Dimensions: 6		
<input type="checkbox"/> W1	100 mm	= l
<input type="checkbox"/> W2	100 mm	= l
<input type="checkbox"/> W3	115 mm	= b
<input type="checkbox"/> t1	12.5 mm	= a
<input type="checkbox"/> t2	12.5 mm	= a
<input type="checkbox"/> t3	20 mm	= d

④ Adjust the dimensions in the Details View, and click on Generate.

⑤ Final result visualization of your Cross Section.

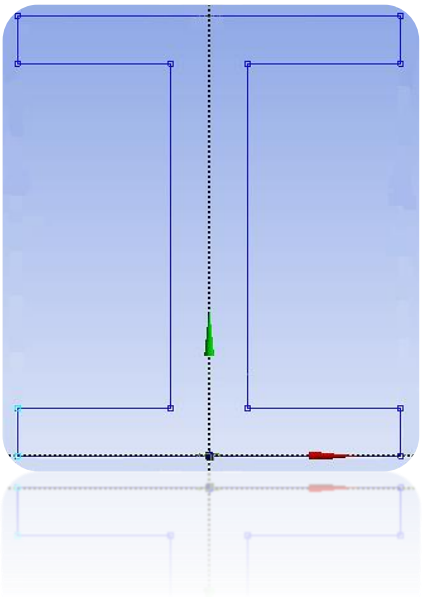

⑥ Assign the Cross Section to your Line Body.

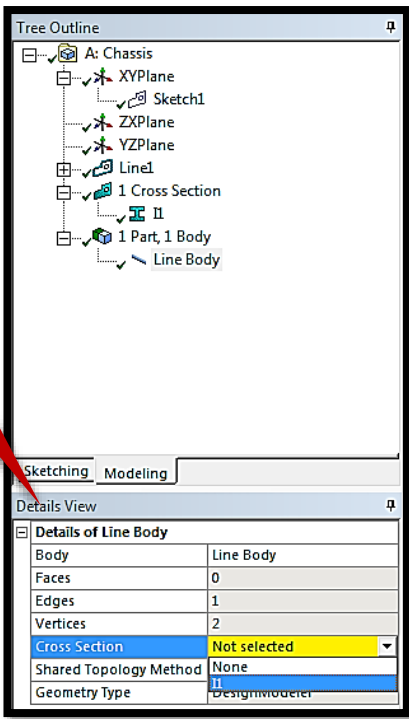

⑦ Get to the View tab/ Cross Section Solids.

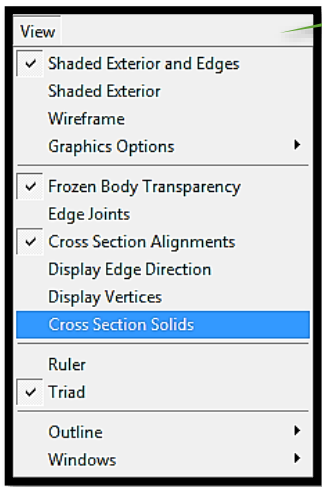

⑧ To activate Cross Section Solid View, in the Graphics tab.

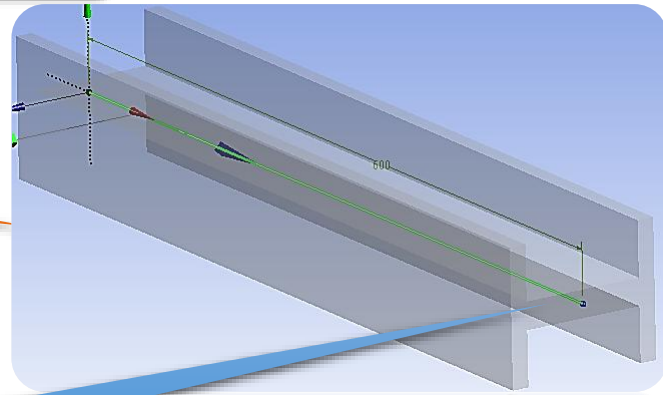

⑨ You can see that the orientation of the Cross Section is wrong. To fix this activate Selection Filter: Edges and select the original Line (Green line in the figure).



Details View	
Line-Body Edge	
Alignment Mode	Selection
Cross Section Alignment	Vector
Alignment X	0
Alignment Y	0
Alignment Z	1
Rotate	90 °
Reverse Orientation?	No

⑩ Input 90° at the Rotate option in the Details View window.

⑪ Final geometry visualization outcome.

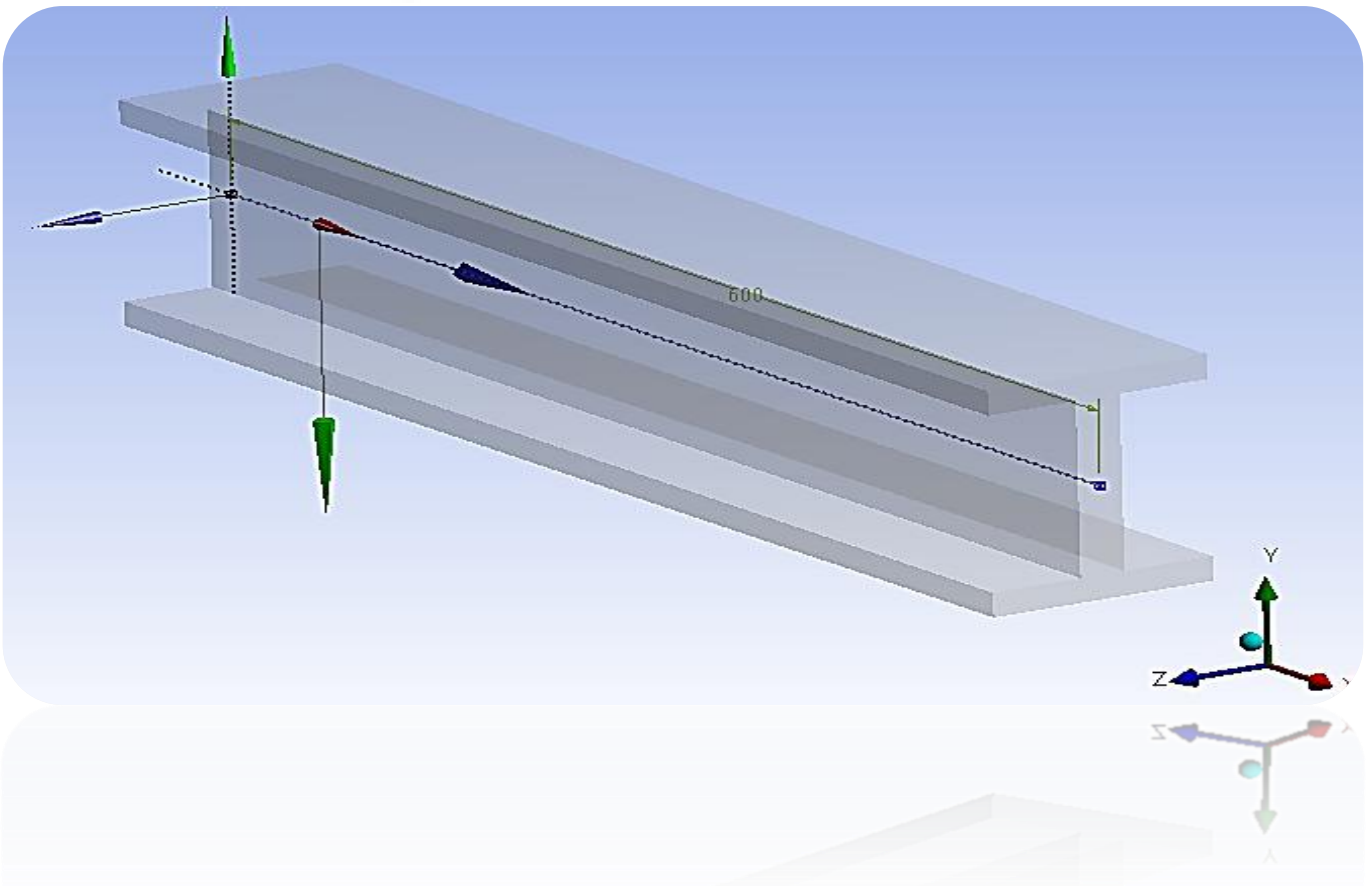

### 5.4.i Set Up Mesh Controls

Your Geometry Body is ready, close DesignModeler and open up Mechanical GUI, by double clicking on the Model from the Static Structural System (we do not need to make any modifications in this case before opening up Mechanical GUI).

The screenshot shows the ANSYS Mechanical GUI. On the left, the Outline Tree is visible with 'Mesh' selected. The Mesh Control panel is open, and 'Sizing' is highlighted. The Details view for 'Edge Sizing' is shown at the bottom left, with the following settings:

Details of "Edge Sizing" - Sizing	
<b>Scope</b>	
Scoping Method	Geometry Selection
Geometry	1 Edge
<b>Definition</b>	
Suppressed	No
Type	Element Size
<input type="checkbox"/> Element Size	5, mm
Behavior	Soft
Bias Type	No Bias

On the right, a context menu is open for the 'Mesh' object, with 'Generate Mesh' selected.

① To set up mesh controls, highlight Mesh from the Outline Tree, go to Mesh Control and choose Sizing.

③ Right click on Mesh, Generate Mesh.

② Input the Line Body for Geometry, in the Details View, and change the Element Size from Default to 5mm.

④ Mesh outcome.

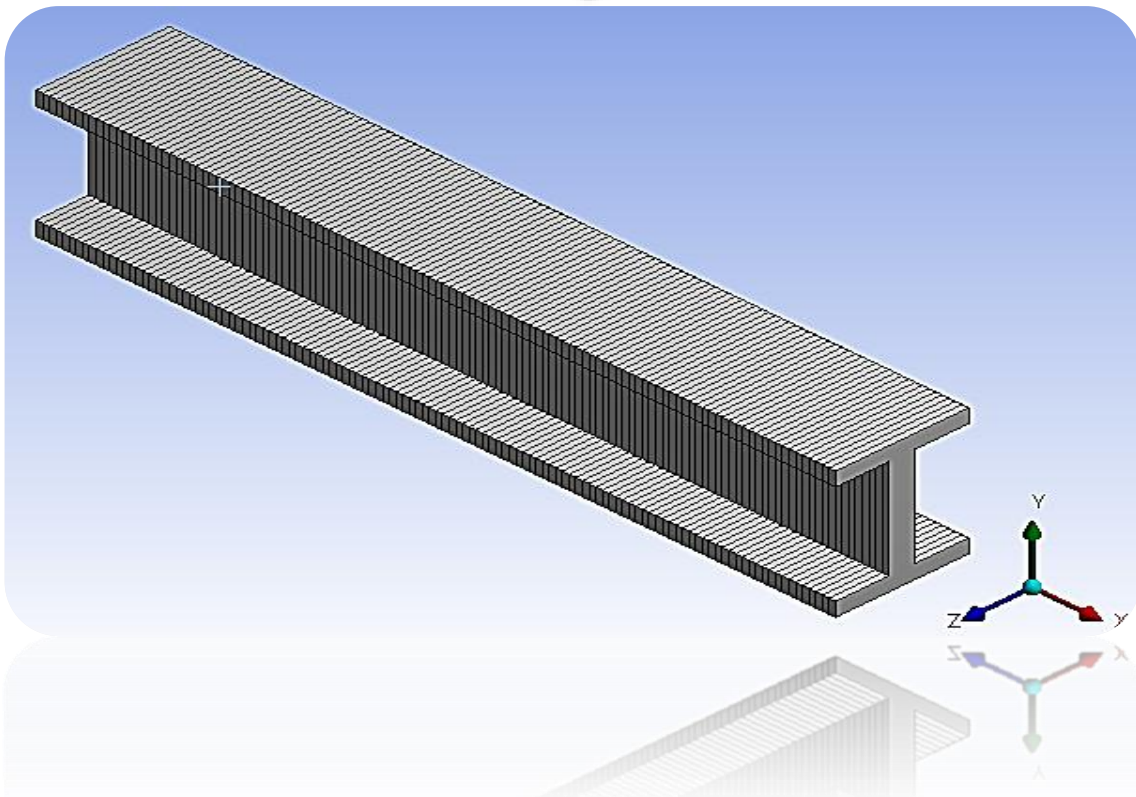

5.5.i Set Up Supports, Loads

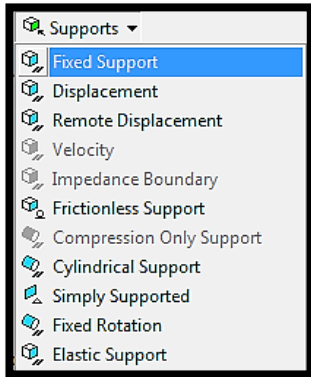

① Highlight Static Structural from the Outline Tree, go to Supports and choose Fixed Support [for point "A"].

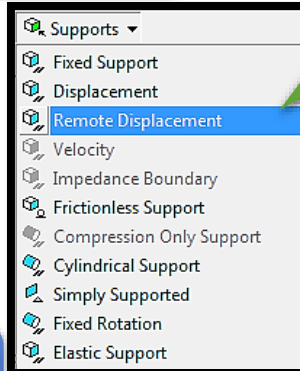

④ Highlight Static Structural from the Outline Tree, go to Supports and choose Remote Displacement [for point "O"].

⑤ For Geometry, choose the other end vertex. At that end, we want  $U_x = 0$ , and  $R_z = 0$ , the rest Degrees of Freedom are going to stay default, Free.

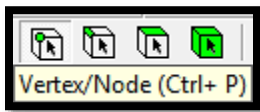

② Activate Vertex/Node Filter, to be able to select the vertex where your Fixed Support will be.

③ Input one of the vertexes for Geometry.

Details of "Fixed Support"	
<b>Scope</b>	
Scoping Method	Geometry Selection
Geometry	1 Vertex
<b>Definition</b>	
ID (Beta)	34
Type	Fixed Support
Suppressed	No

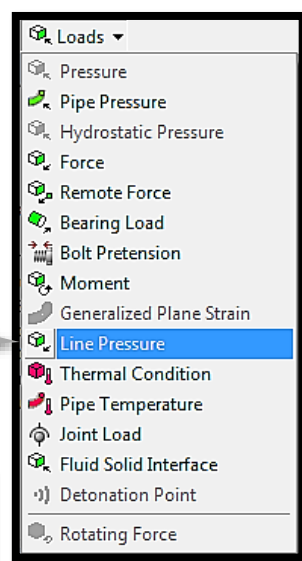

⑥ Regarding the Load case, we need to Apply Linear Pressure on the whole Line Body, to achieve this we need to use Line Pressure concept.

Details of "Remote Displacement"	
<b>Scope</b>	
Scoping Method	Geometry Selection
Geometry	1 Vertex
Coordinate System	Global Coordinate System
<input type="checkbox"/> X Coordinate	600. mm
<input type="checkbox"/> Y Coordinate	0. mm
<input type="checkbox"/> Z Coordinate	0. mm
Location	Click to Change
<b>Definition</b>	
ID (Beta)	38
Type	Remote Displacement
<input type="checkbox"/> X Component	0. mm (ramped)
Y Component	Free
Z Component	Free
Rotation X	Free
Rotation Y	Free
<input type="checkbox"/> Rotation Z	0. ° (ramped)
Suppressed	No
<b>Advanced</b>	

Details of "Line Pressure"	
<b>Scope</b>	
Scoping Method	Geometry Selection
Geometry	1 Edge
<b>Definition</b>	
ID (Beta)	41
Type	Line Pressure
Define By	Components
Coordinate System	Global Coordinate System
<input type="checkbox"/> X Component	0. N/mm (ramped)
<input type="checkbox"/> Y Component	-1000. N/mm (ramped)
<input type="checkbox"/> Z Component	0. N/mm (ramped)
Suppressed	No

⑦ Select our Line, for Geometry.

⑧ Change the Coordinate System to Global Coordinate System.

⑨ Check your Triad and input our data for Pressure. Mine is a negative Y Component.

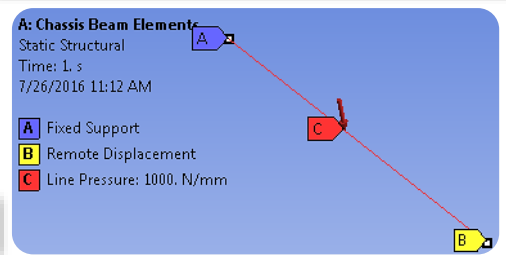

⑩ Why 1.000 N/mm and not 10MPa [given data] ?

The equation for the Pressure equals with  $P = F/S$ , where **F = Force** and **S = Area** of the surface where the Force is applied. [**F = P\*S**]

The equation for the Linear Pressure equals with  $q = F/l$ , where **F = Force** and **l = Length** of the Beam. [**F = q\*l**]

In this study case we want the same Forces, consequently  $P*S = q*l \Rightarrow q = P * S/l$  ①

**S = h\*w** [h=height, w=width]

①  $\rightarrow q = 10 * 60000 / 600 \Rightarrow q = 1000 \text{ N/mm}$

### 5.6.i Set Up Solution Outcome Branch

① Highlight Solution branch, and choose Total Deformation, and Beam Tools to be calculated.

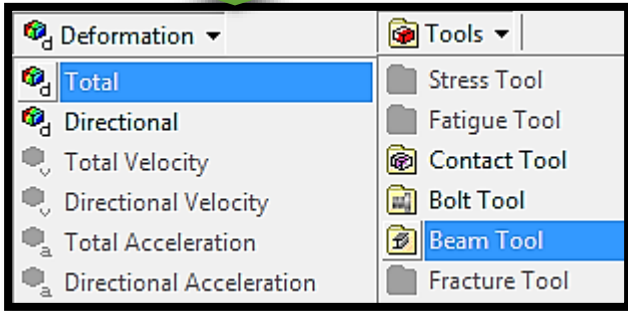

② Highlight Solution branch, and Evaluate All Results.

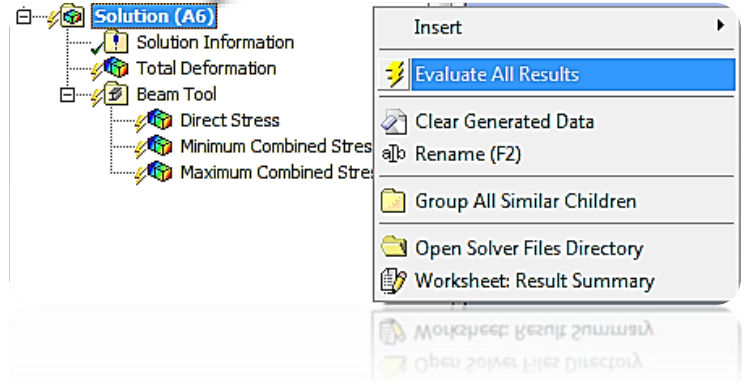

### 5.7.i View the Results

① This option, allows you to visualize the results in a more apparent visualization.

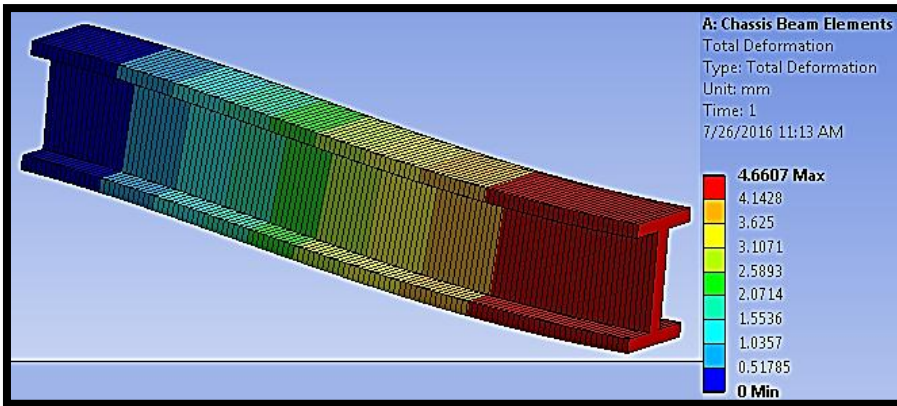
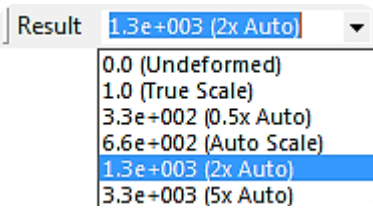

- Checking Boundary Conditions:
- Symmetry (no rotation of the profile).
  - Deformed Shape.

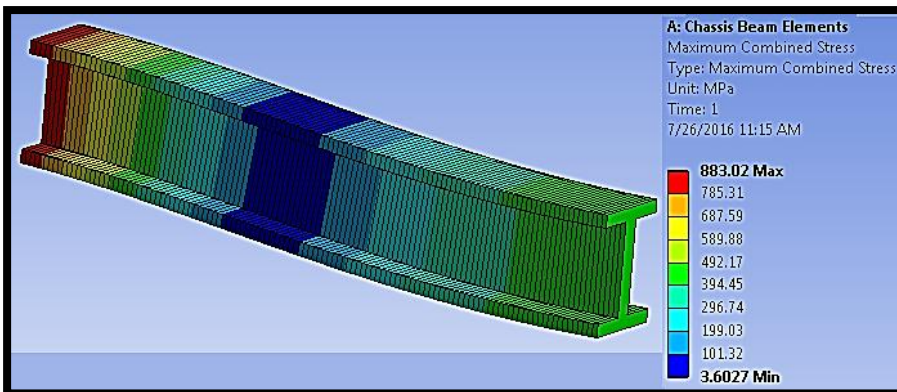

## ii. Solid Elements

### 5.2.ii Start Up

Next part of this chapter would be, creating the same geometry, with the same boundary conditions, the same loads. Only difference would be that, this time we will use solid elements for our analysis. Open up your previous study case (Car Chassis), and create a new Static Structural System, check again your Engineering Data to much with our data and leave everything else as default: open up DesignModeler, and change your Units to Millimeters.

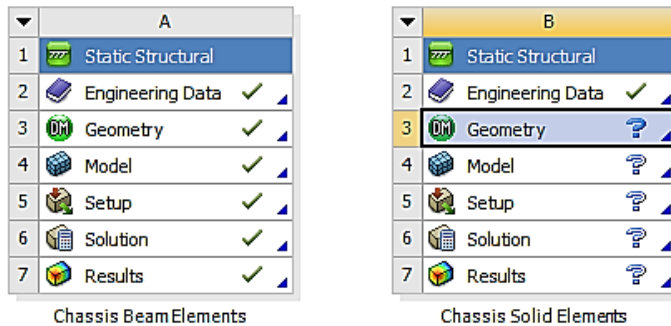

① Double- click on Geometry. When DesignModeler loads, change Units parameter to Millimeters

### 5.3.ii Create Body

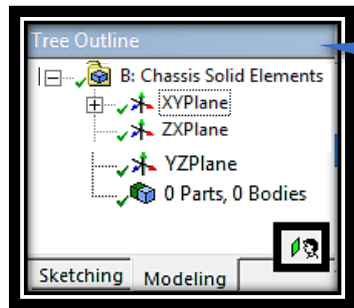

① Highlight XYPlane, go to Sketching tab and select Look at Face/ Plane/ Sketch to adjust your planes.

② We will create a line body, exactly the same as the I Cross Section we used for the Beam Elements case.

③ For easiness, select Polyline to create the line body.

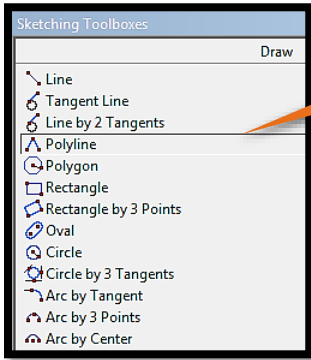

④ Draw the exact same sketch as shown in the figure.

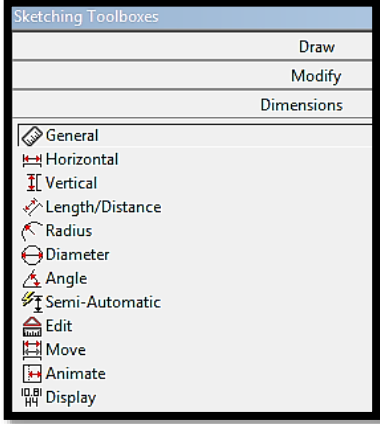
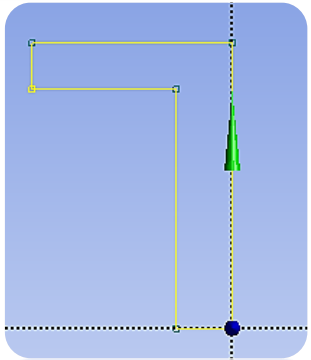

⑤ Get to Dimensions tab, and select General.

⑥ Assign the given dimensions, and input our data values.

Dimensions: 4		
<input type="checkbox"/> H4	10 mm	= $d/2$
<input type="checkbox"/> H5	50 mm	= $l/2$
<input type="checkbox"/> V2	12.5 mm	= $a$
<input checked="" type="checkbox"/> V3	57.5 mm	= $h/2$

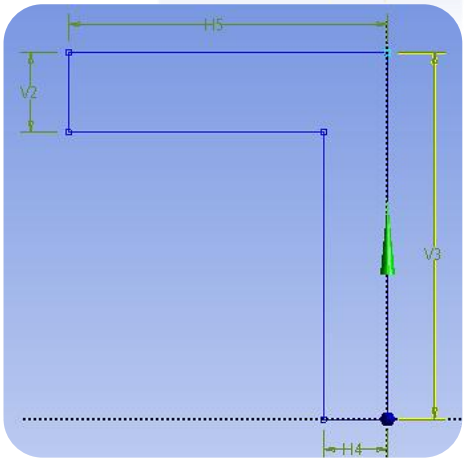

⑦ Getting back to Modelling tab, highlight Sketch1, go to Create/ Extrude.

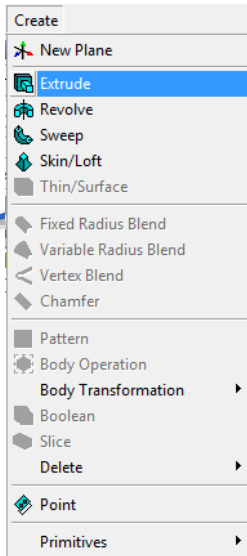

⑧ Press Apply to assign Sketch1 to the Geometry option. Leave the rest default except FD1, Depth which is our length dimension [m].

Details View	
Details of Extrude1	
Extrude	Extrude1
Geometry	Sketch1
Operation	Add Material
Direction Vector	None (Normal)
Direction	Normal
Extent Type	Fixed
<input type="checkbox"/> FD1, Depth (>0)	600 mm
As Thin/Surface?	No
Merge Topology?	Yes



⑨ Click on Generate.

⑩ As you noticed, our Geometry is symmetric, that is why we created only the 1/4 of the whole body.

⑪ To create the rest of the body, we will use the Mirror command, go to Create/ Body Transformation/ Mirror.

⑫ Select our whole extruded body for Bodies, and for Mirror Plane choose YZPlane.

Details View	
Details of Mirror1	
Mirror	Mirror1
Preserve Bodies?	Yes
Mirror Plane	YZPlane
Bodies	1

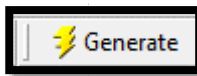
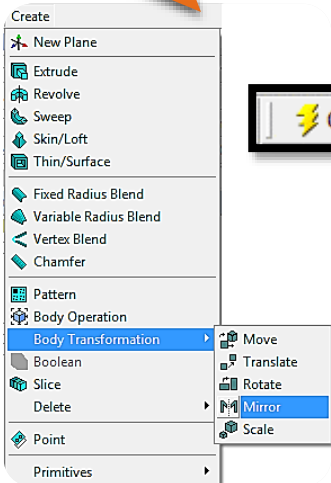

⑬ Click on Generate.

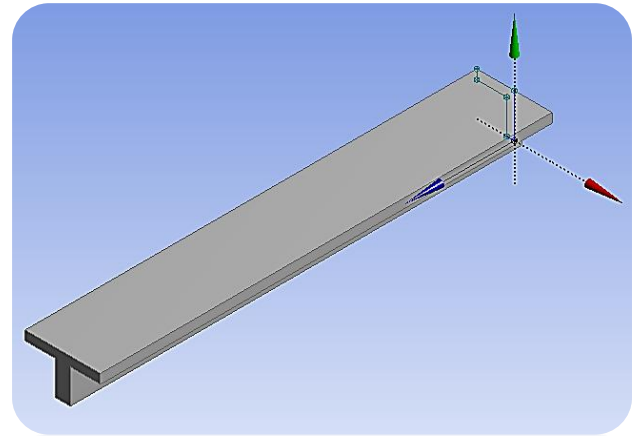

⑬ Do the same now to create the lower part of the geometry missing [ZXPlane].

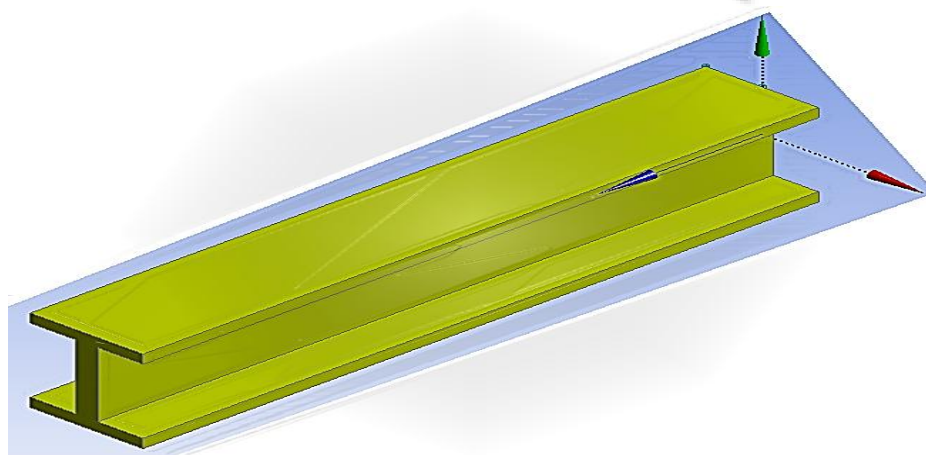

### 5.4.ii Set Up Mesh Controls

After finishing with sketching the geometry, close DesignModeler and open up Mechanical GUI, by double clicking on the Model from the Static Structural System (there is no need to make any modifications).

① We are going to use the same mesh controls, as we did for the Beam Elements case.

② Highlight Mesh from the Outline Tree, go to Mesh Control and choose Sizing again. Afterwards change the Element Size from Default to 5mm.

Definition	
Suppressed	No
Type	Element Size
<input type="checkbox"/> Element Size	5. mm
Behavior	Soft
Bias Type	No Bias

③ We need to mesh the whole solid body, for the Geometry option, right click anywhere in the Display screen and choose Select All.

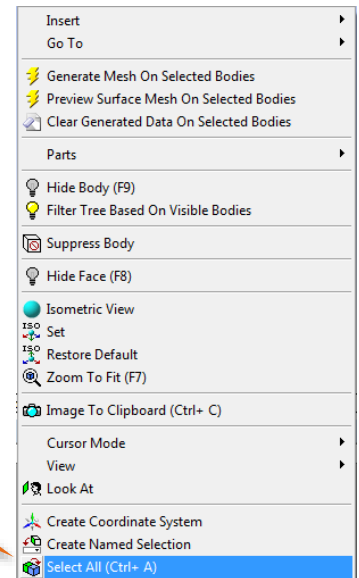

④ Mesh outcome.

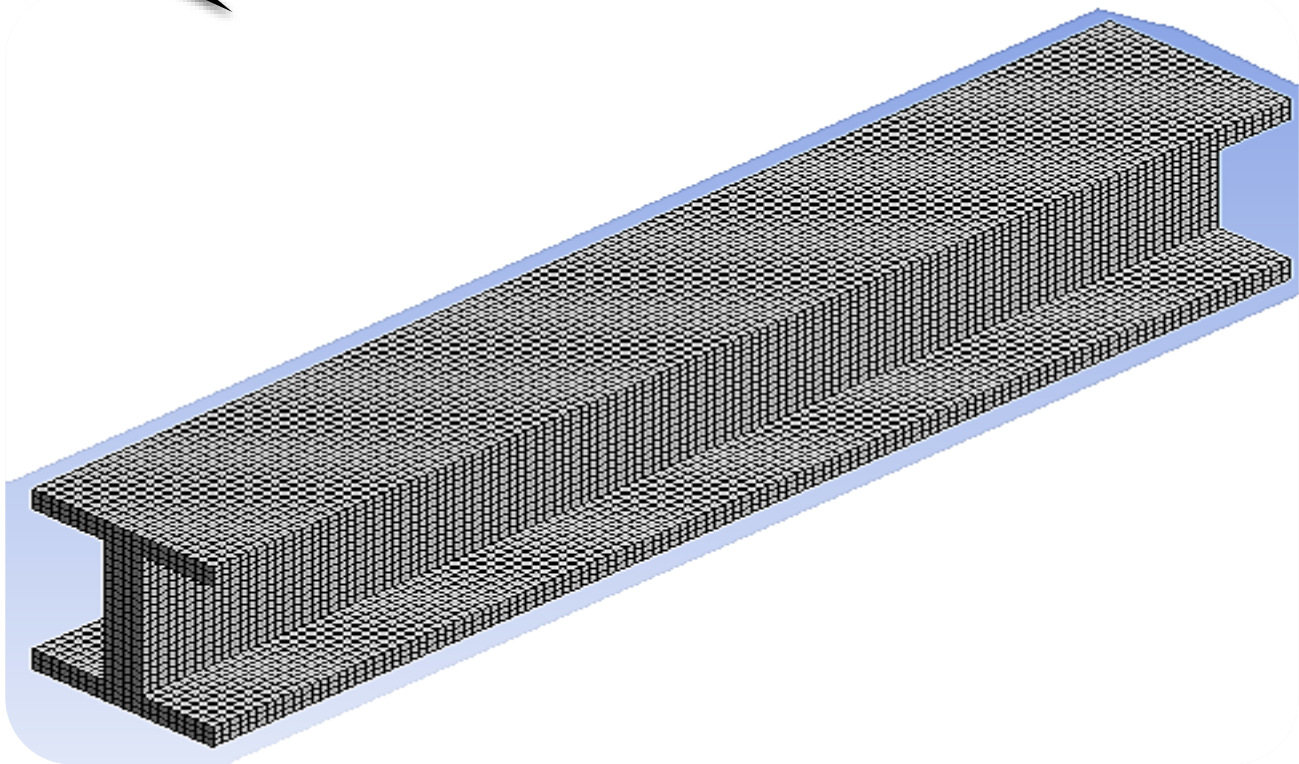

### 5.5.ii Set Up Supports, Loads

- ① For the Supports and Load set up, we still need the same restrictions like in the Beam Element case. Fixed Support to one end, Remote Displacement on the other with  $U_x = 0$  and  $R_z = 0$ , and 10MPa Pressure on  $-Y$  Plane.

**Note:** There is a chance that your axis might be different than the ones in the Beam Elements case, so be extra careful when you input the restrictions. [ $R_z = 0$  changed to  $R_x = 0$  for me]

- ② Choosing Pressure instead of Linear Pressure has no difference at all in the Solid Elements.

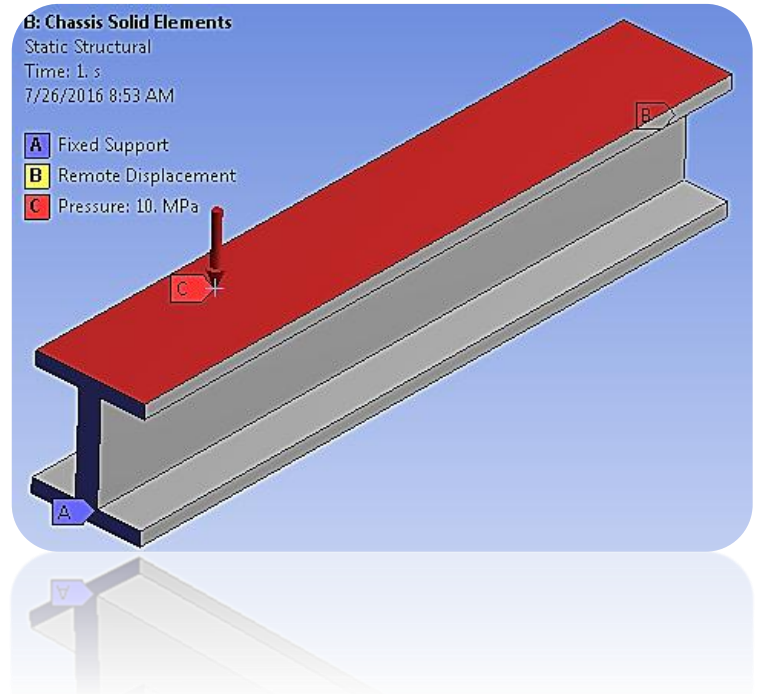

### 5.6.ii Set Up Solution Outcome Branch

- ① Highlight Solution and choose Total Deformation and Normal Stress for the computational analysis.

- ② Your Outline Tree should look like this figure.

- ③ Right click on Solution, and choose Evaluate All Results.

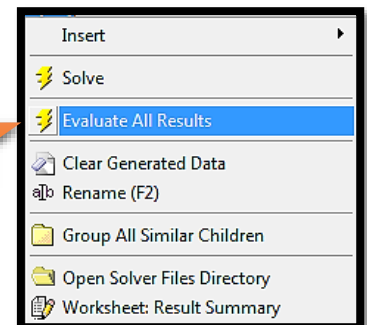
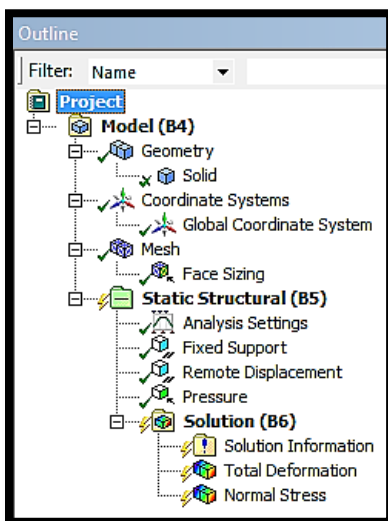

### 5.7.ii View the Results

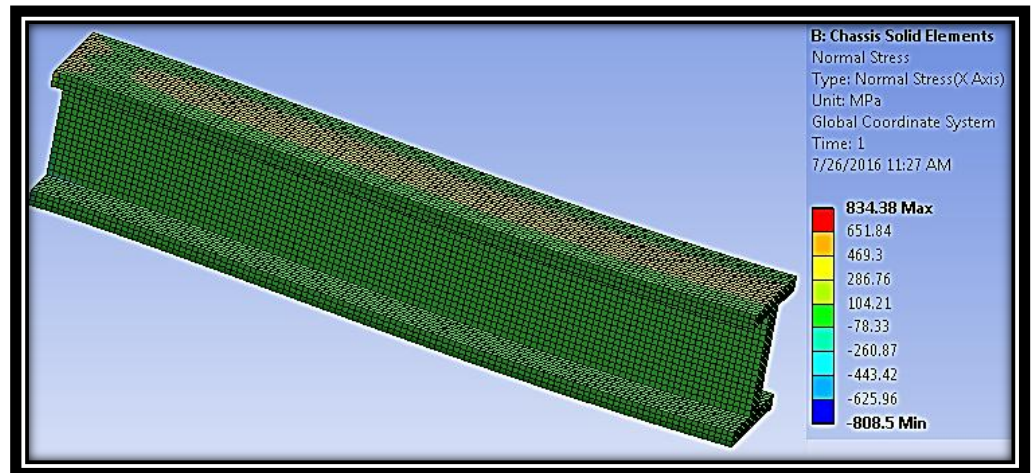
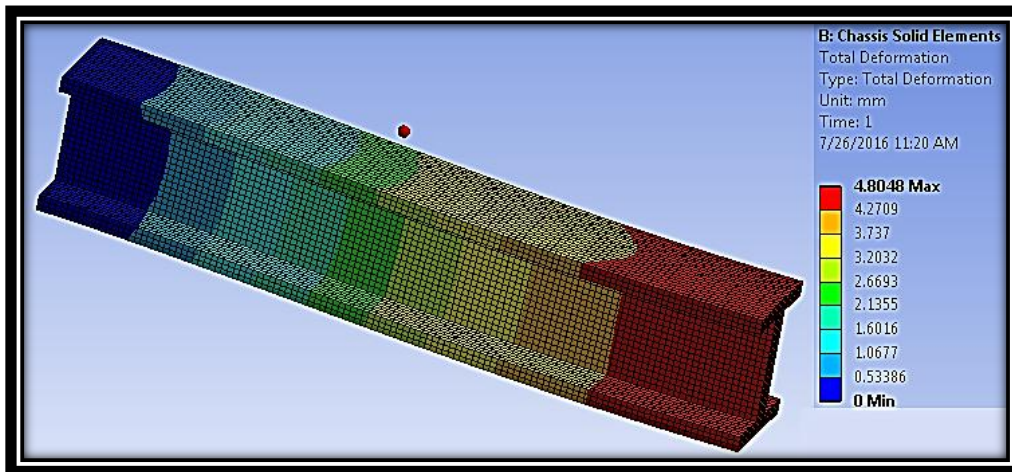

Checking the right deformation behavior, like in the previous outputs.

### iii. Surface Elements

#### 5.2.iii Start Up

In this study case, it will not be needed to create a new Static Structural System and sketching the geometry from all over again. There is an easier way by Duplicating the Solid Elements study case, with this option the newly created Static Structural System has the exact same geometry, mesh and boundary conditions like the Static Structural System that we Duplicated. After Duplicating it, open up DesignModeler to make some modifications regarding the Surface Elements.

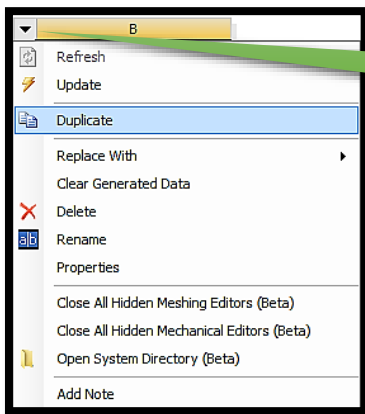

① Right click at the little black arrow in order to pop up this list, and choose Duplicate.

② All of your Static Structural Systems.

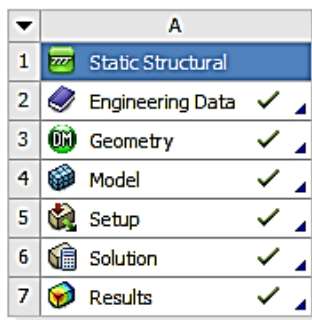

Chassis Beam Elements

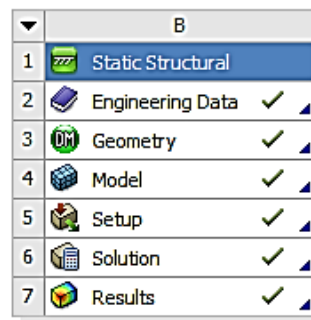

Chassis Solid Elements

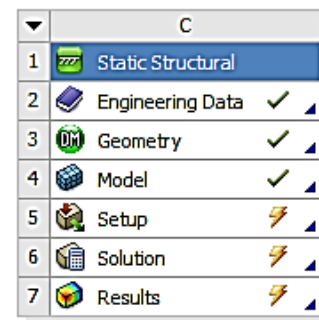

Chassis Surface Elements

#### 5.3.iii Create Body

One of the better features of Workbench's DesignModeler is the Mid-Surface Extraction tool. This tool is fairly simple to use, and after some practice, you will be creating shell models in no time. The Mid-Surface Extraction utility is located underneath the 'Tools' Menu.

The easiest way to create Mid-Surfaces is to manually go through and select the face pairs. You will notice that after selecting the "top" and "bottom" face, they will appear as two different colors. It is important to note that the order in which you click the two faces determines the "top" and "bottom" of the shell element (important for applying pressures/defining contact). The shell normal is positive going from the pink (2nd pick) to the purple (1st pick) surface.

You can select multiple face pairs, then go back and hit the apply button for "Face Pairs" in the detail window. If there are several face pairs that have the same thickness, you can select one pair, then go back and change the selection type to be automatic. This will fill in some blanks in the details window.

Finally, change "Find Face Pairs Now" to be "Yes" and DesignModeler will go out and find all face pairs that meet this criteria. Hit generate and all of your midplanes will be generated, and all thicknesses will be stored for later use in Simulation.

There is no need for us to change the Units again, since our new Static Structural System has the same data inputs like the previous one (Solid Elements), now we need to create Surface models out of the Solid Body.

① To do that, go to Tools/ Mid- Surface.

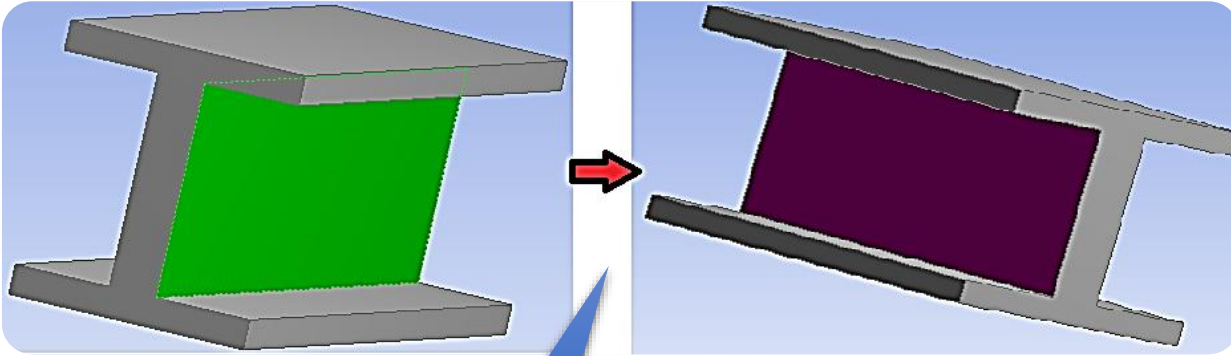
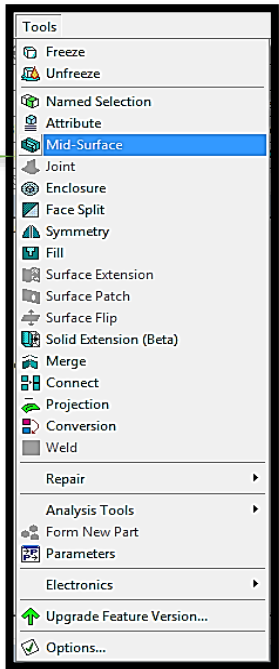

② For the face pairs, we will need to search which face pairs with which. Starting with the "easy to locate" middle Face Pair. Choose one face (it will turn green) and then by holding Ctrl choose the other one (when both faces are correctly chosen they both will turn into dark red).

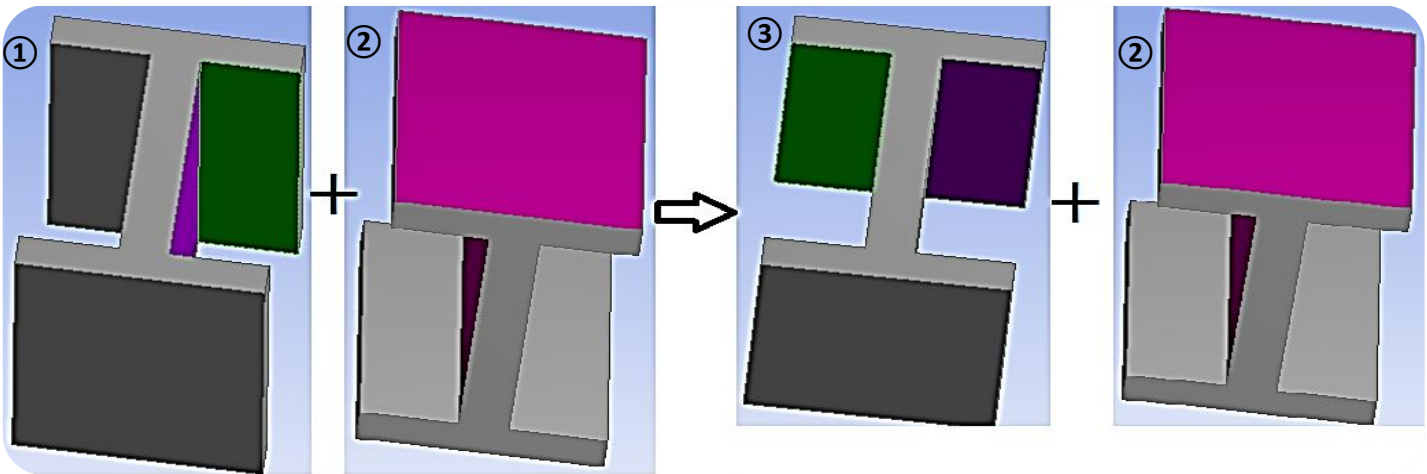

③ This part of the geometry gets trickie. That is because DesignModeler does not allow you to select all the faces that you want to pair, at once. So, firstly you will select #1 and by holding Ctrl you will select #2. Afterwards, you need to choose the other side face #3 and again with Ctrl select the top face #2.

④ With the same way, pair the faces that are located right on the opposite side of the ones that we just paired.

⑤ Change the Selection Method to Automatic.

⑥ Adjust Minimum and Maximum Threshold as shown here.

Details View	
Details of MidSurf1	
Mid-Surface	MidSurf1
Face Pairs	5
Selection Method	Automatic
Bodies To Search	Visible Bodies
Minimum Threshold	2 mm
Maximum Threshold	10 mm
Find Face Pairs Now	No
<input type="checkbox"/> FD3, Selection Tolerance (>=0)	0 mm
<input type="checkbox"/> FD1, Thickness Tolerance (>=0)	0.0005 mm
<input type="checkbox"/> FD2, Sewing Tolerance (>=0)	0.02 mm
Allow Variable Thicknesses	No
Extra Trimming	Intersect Untrimmed with Body
Ambiguous Face Delete	All
Preserve Bodies?	No

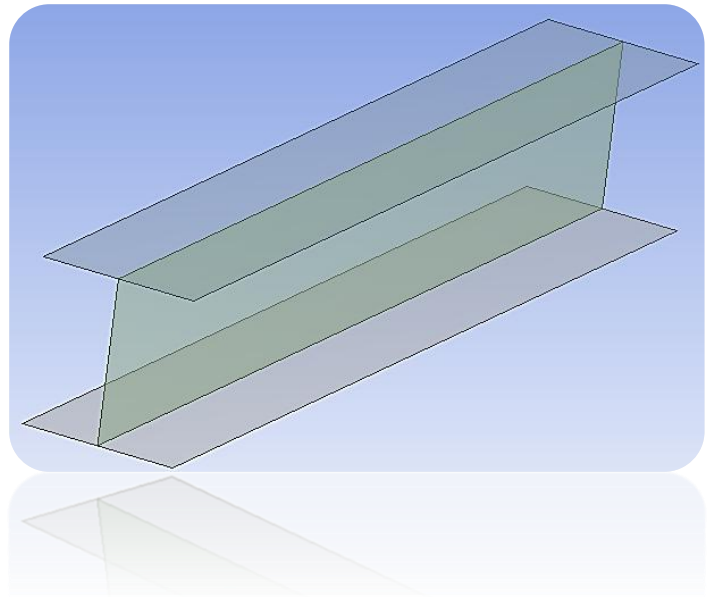
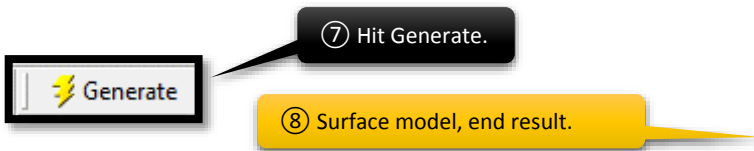

### 5.4.iii Set Up Mesh Controls

We are done with the DesignModeler, so feel free to close the window, and open Mechanical GUI by double clicking at the Model from the Static Structural System. A pop up window will appear asking you if you want to read the up-stream data, which means that the Mechanical GUI will automatically load the new changes we made in the DesignModeler, click Yes.

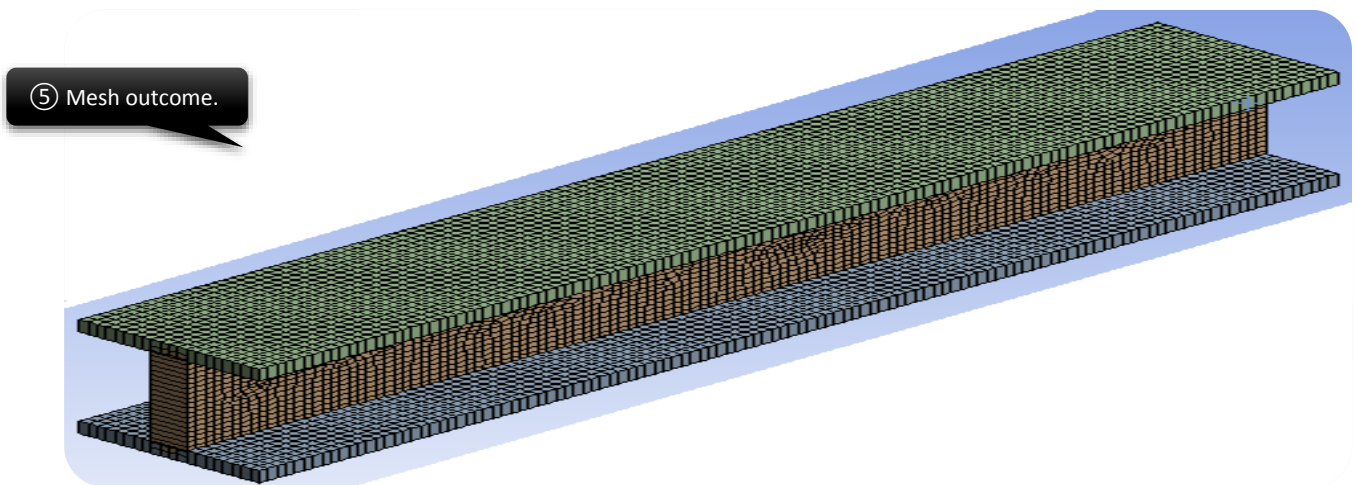
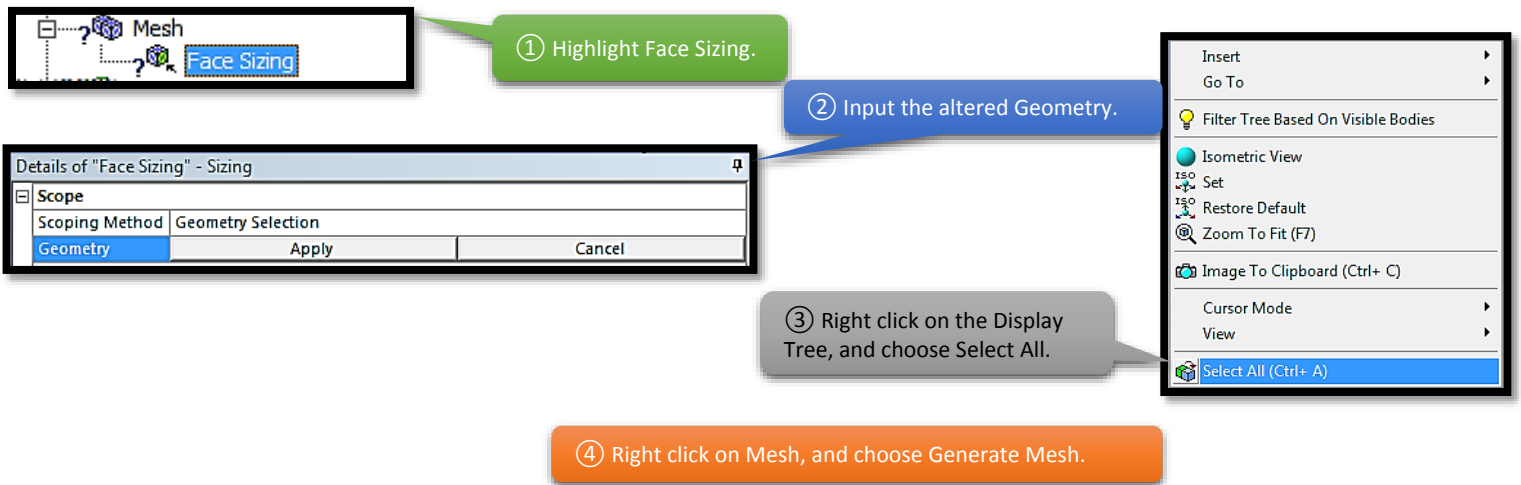

### 5.5.iii Set Up Supports, Loads

As you probably already understood, we are not going to change the mesh, the supports, the loads or the solution outcomes. Thanks to the Duplication the parameters are already settled and we just need to define the new changed geometry.

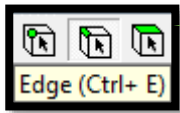

① Highlight Fixed Support, activate Edge selection filter, and choose the Edges that we want our Fixed Support to be located.

② Highlight Remote Displacement, with the Edge selection filter activated, and choose the Edges on the opposite side for our Remote Displacement.

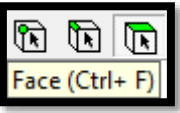

③ Highlight Pressure, activate Face selection filter, and choose the two top faces where our load is located.

④ Right click on Static Structural from the Outline Tree and choose Solve.

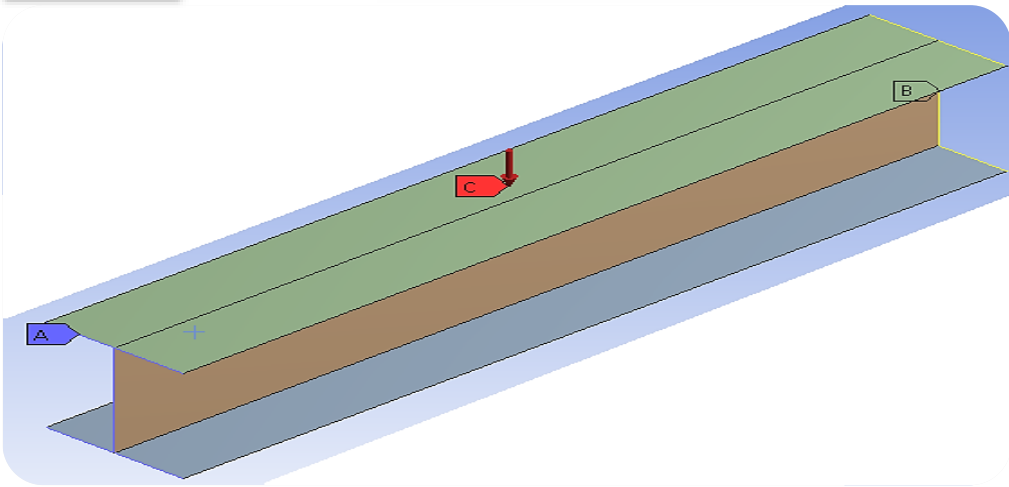
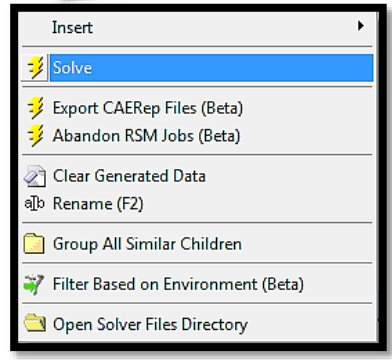

### 5.6.iii View the Results

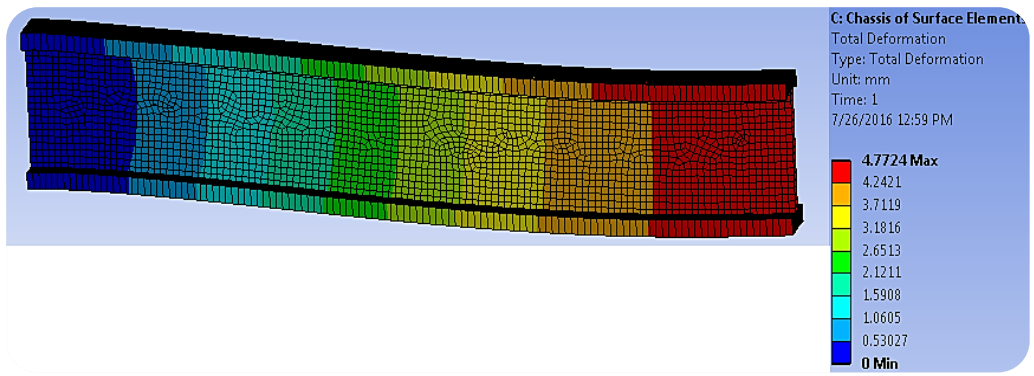

Checking the right deformation behavior, like in the previous outputs.

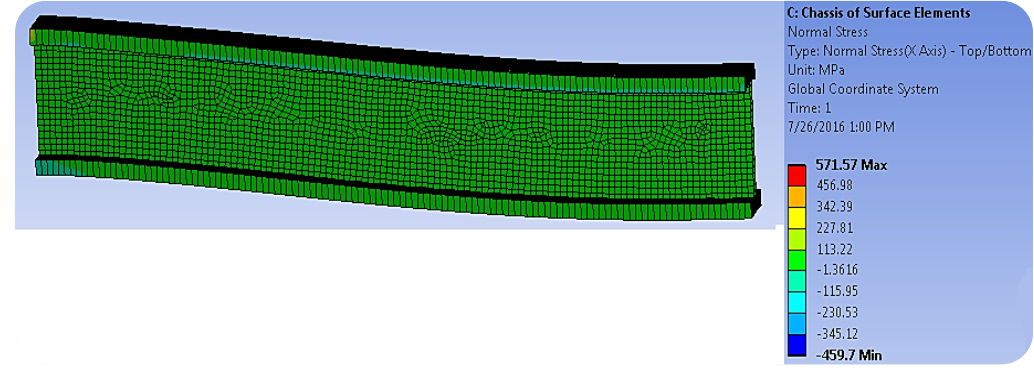

#### **iv. Type of Elements Comparison**

We could compare and comment the results of all 3 different type of elemets.

## CHAPTER\_VI: TUNING FORK

## 6.1 Problem Description

In this chapter, we want to perform a Modal Analysis to investigate the natural frequencies of a Tuning Fork. The specific tuning fork is designed to tune chamber A 440Hz. In the case that the tuner does not meet the stated requirements, we will modify the geometry, material or mass of the tuner in order to get the correct frequency output.

For that reason, we will set from the start some parameters (Parametric Model) which will help us to modify the geometry's dimensions easier and without the need to sketch the tuning fork from scratch.

**Initial Dimensions**

$a = 2.5 \text{ mm};$   $l = 100 \text{ mm};$   
 $b = 20 \text{ mm};$   $c = 5 \text{ mm};$   
 $d = 8 \text{ mm};$   $R_2 = 2 \text{ mm};$   
 $R_7 = 7 \text{ mm};$

**Material**

Model Material: homogeneous, isotropic and linear elastic continuum.

Structural Steel: Young's Modulus = 200 GPa;  
Poisson's Ratio = 0.3;

Copper Alloy: Young's Modulus = 110 GPa;  
Poisson's Ratio = 0.34;

**Supports**

Fixed Support to "b-dimension" line (drawing will help).



Symmetric model

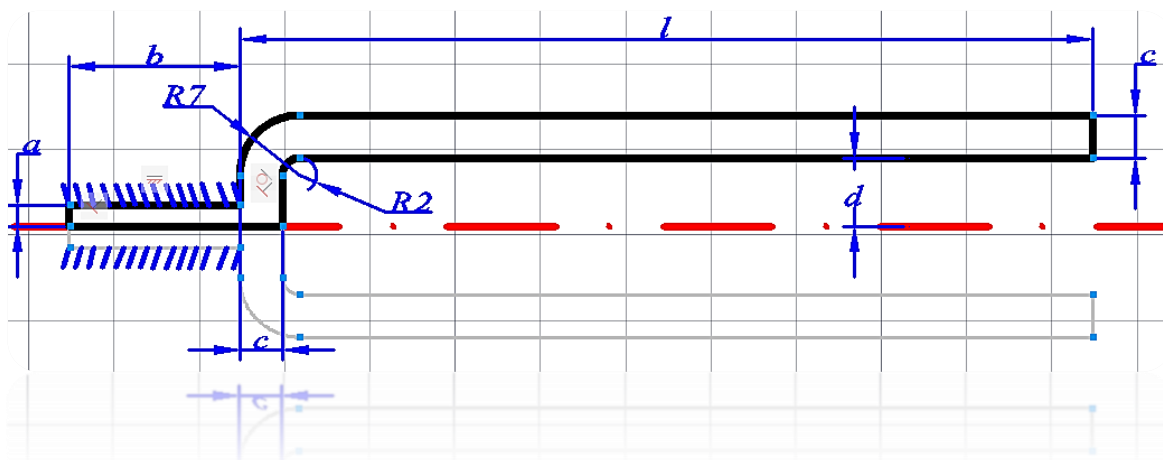

## 6.2 Start Up

Open up ANSYS Workbench, locate Modal from the Toolbox/ Analysis Systems and drag and drop it to the Project Schematic as you did with the Static Structural Systems. Save your study case to a proper destination folder, head to the Engineering Data tab to make sure that your material properties match with the given ones.

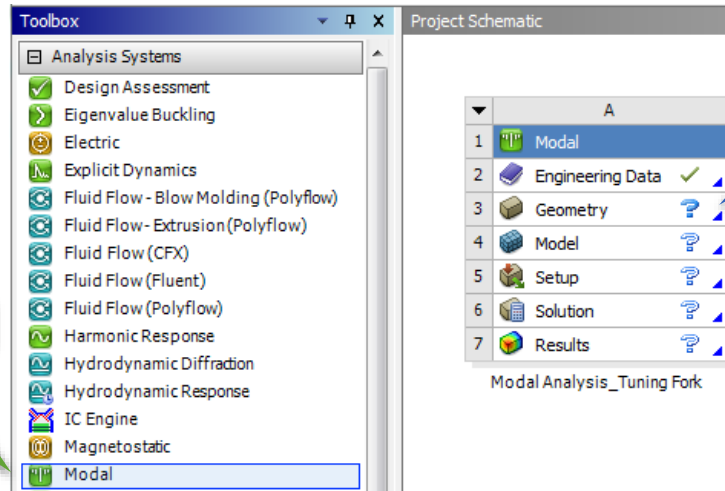

① Select Modal Analysis System.

② Double-click on Geometry to start sketching.

## 6.3 Create Body

When the DesignModeler loads, make sure to change the Units type to Millimeter and move to the Sketching tab to create our tuning form geometry.

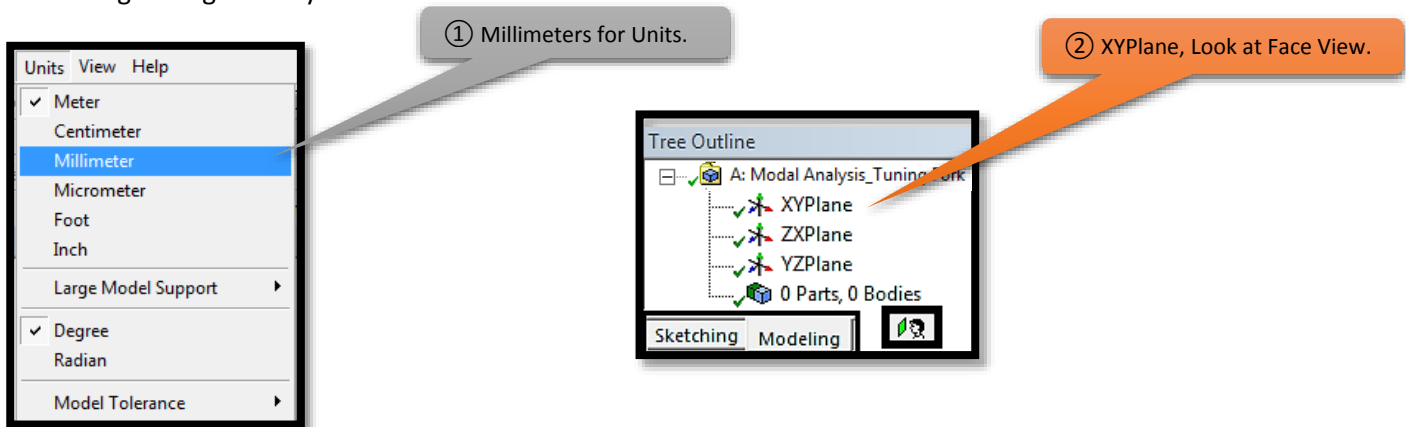

① Millimeters for Units.

② XYPlane, Look at Face View.

As you noticed in the Problem Description paragraph, our model is symmetric, meaning that we got the option here to sketch only half of the geometry body without having differences at the end results. So, getting back to the sketching part, we will need to create a sketch like the figure below.

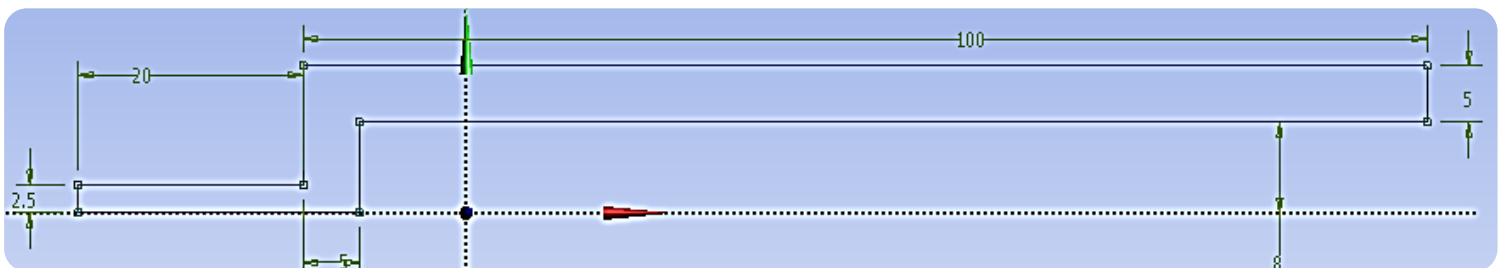

**③ Our dimensions.**

Dimensions: 6		
<input type="checkbox"/> H1	100 mm	= $l$
<input type="checkbox"/> H3	20 mm	= $b$
<input type="checkbox"/> H5	5 mm	= $c$
<input type="checkbox"/> V2	5 mm	= $c$
<input type="checkbox"/> V4	2.5 mm	= $a$
<input type="checkbox"/> V6	8 mm	= $d$

**④ Head back to Modeling tab.**

Sketching | Modeling

**⑤ Go to Create/ Extrude.**

**⑥ Select Sketch1 for Geometry.**

**⑦ Input 8mm for the Extrusion Depth (thickness).**

**⑧ Hit Generate.**

**⑨ Go to Create/ Fixed Radius Blend, to create the radius.**

**⑩ Input 7mm for the "bigger" radius fillet.**

**⑪ Activate Edges Selection Filter, to be able to choose the correct Edge..**

**⑫ Hit Generate.**

**⑬ Do the same, for the "smaller" radius part, FD1, Radius = 2mm.**

Selection Filter: Edges (Ctrl+ E)

Details View

Details of Extrude1		
Extrude	Extrude1	
Geometry	Sketch1	
Operation	Add Material	
Direction Vector	None (Normal)	
Direction	Normal	
Extent Type	Fixed	
<input checked="" type="checkbox"/> FD1, Depth (>0)	8 mm	
As Thin/Surface?	No	
Merge Topology?	Yes	
Geometry Selection: 1		
Sketch	Sketch1	

Details View

Details of FBlend1		
Fixed-Radius Blend	FBlend1	
<input checked="" type="checkbox"/> FD1, Radius (>0)	7 mm	
Geometry	1 Edge	

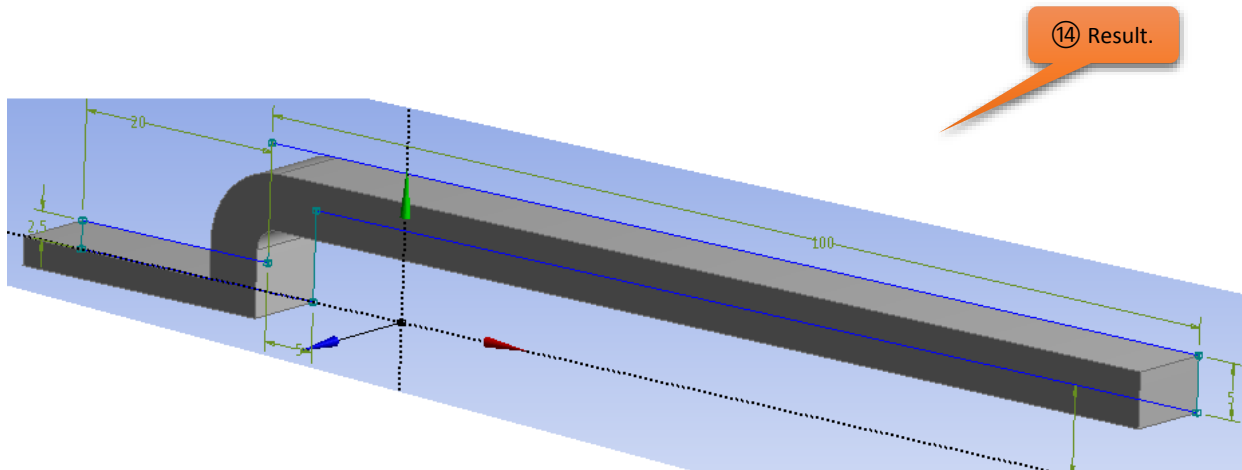

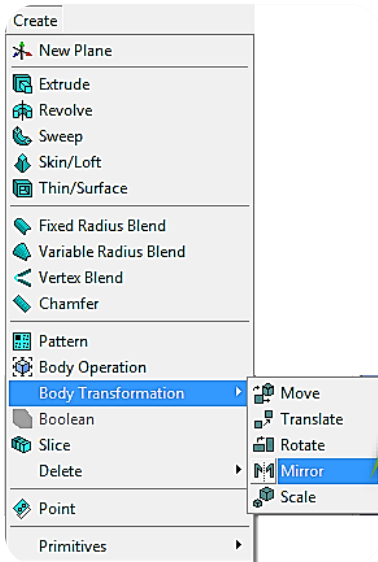

⑮ Go to Create/ Body Transformation/ Mirror, to create the rest of the geometry.

Details View	
Details of Mirror1	
Mirror	Mirror1
Preserve Bodies?	Yes
Mirror Plane	ZXPlane
Bodies	1

⑯ ZXPlane for Mirror Plane, and for Bodies you have to choose the whole body.

⑰ Tree Outline, End result.

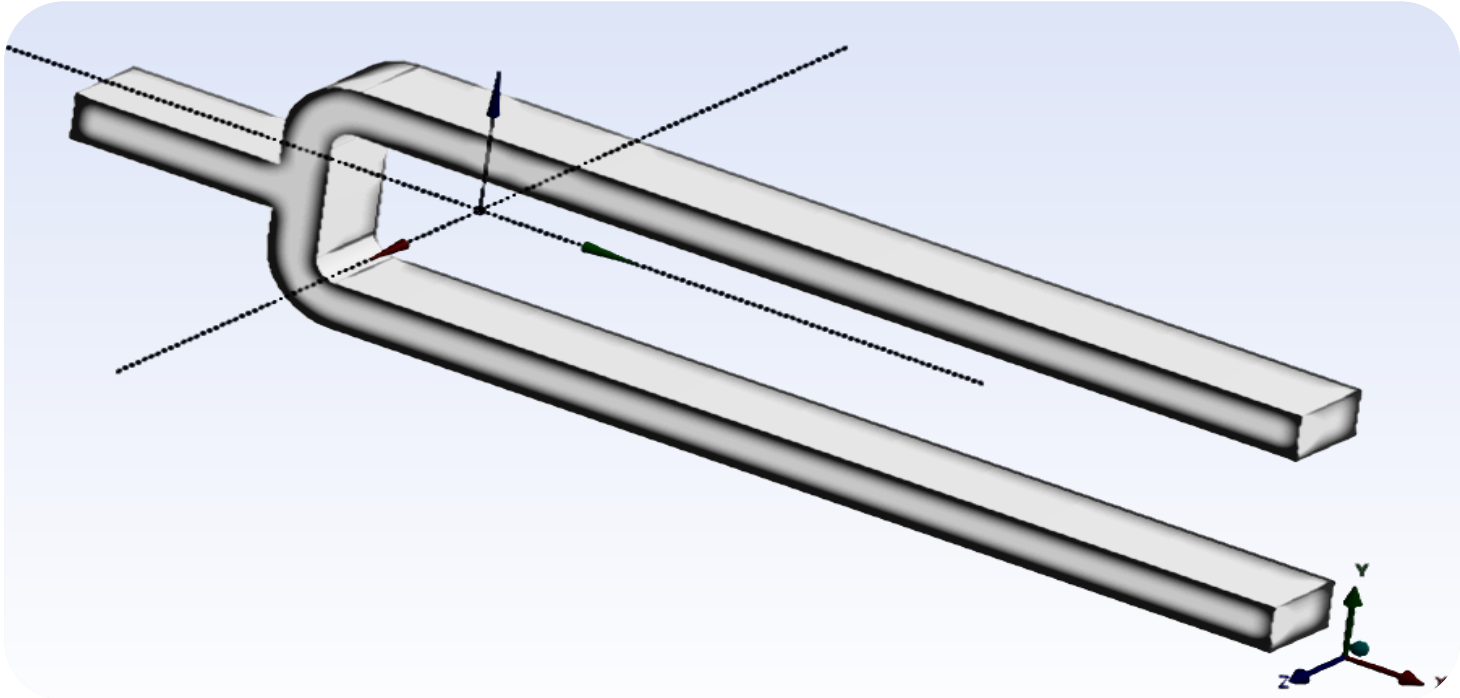
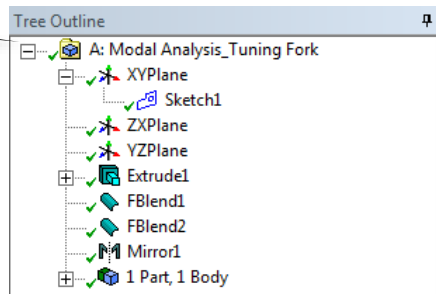

### 6.4 Set Up Mesh Controls

Your Geometry Body is ready, close DesignModeler and open up Mechanical GUI, by double clicking on the Model from the Modal Analysis System (we do not need to make any modifications in this case before opening up Mechanical GUI).

③ Right-click again on Mesh/ Generate Mesh.

② What do we see here??

① Right-click on Mesh/ Show/ Sweepable Bodies.

⑤ Right-click again on Mesh/ Generate Mesh, and you will have similar results.

Sizing	
Use Advanced Size Function	Off
Relevance Center	Coarse
<input type="checkbox"/> Element Size	2.50 mm
Initial Size Seed	Active Assembly
Smoothing	Medium
Transition	Fast
Span Angle Center	Coarse
Minimum Edge Length	3.14160 mm

④ As you can notice we need to change the Element Size to 2.5mm.

### 6.5 Set Up Supports, Loads

① Highlight Modal from the Outline Tree, go to Supports and choose Fixed Support, for Edges "b dimension" and the opposite one.

② Activate Face Selection Filter.

③ Choose the two sides, like shown in the figure, by holding Ctrl.

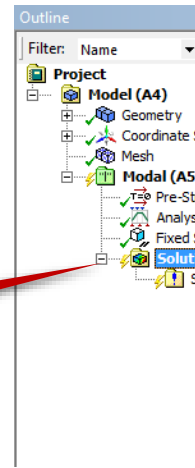
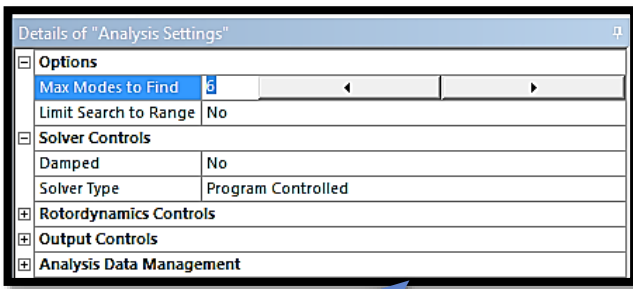

④ Highlight Analysis Setting from the Tree Outline, in the Modal branch, and change "Max Modes to Find" to 8. **WHY?**

⑤ Right-click on Solution/ Solve.

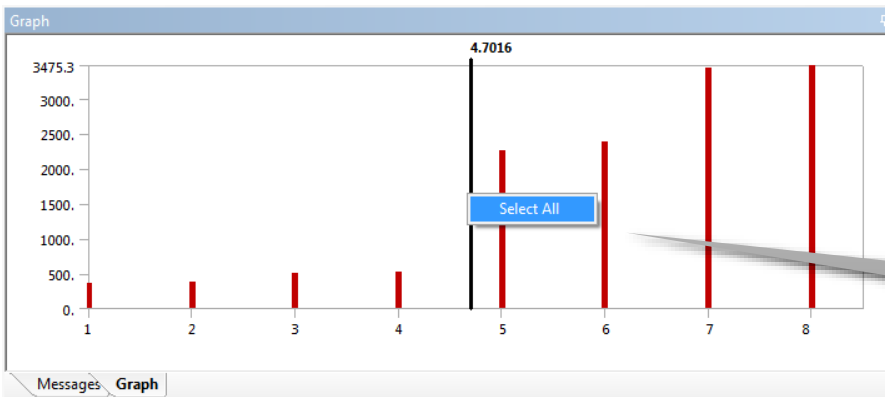

Mode	Frequency [Hz]
1	357.84
2	376.1
3	503.74
4	519.1
5	2261.6
6	2376.
7	3435.5
8	3475.3

⑥ When the analysis end, you will have the same Graph and Tabular Data outputs.

⑦ Select a point by clicking anywhere inside the Graph, right click and choose select all.

⑧ When everything is selected, right-click again anywhere inside the Graph, and choose Create Mode Shape results.

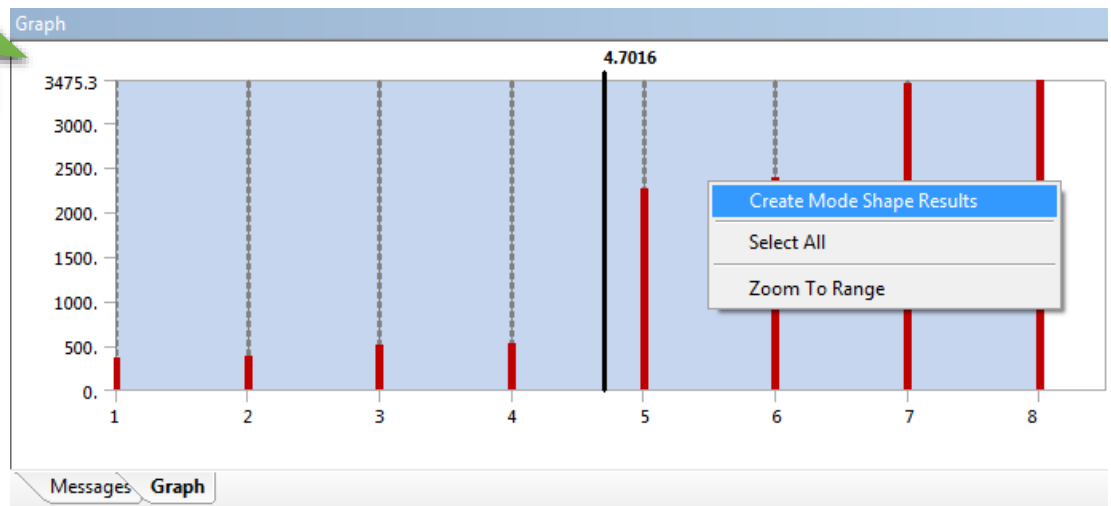

⑨ This option will give us the Tree Outline outcome you see on this figure.

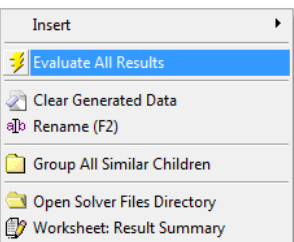
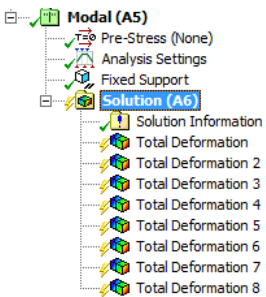

⑩ Right-click on Solution/ Evaluate All Results.

### 6.6 View the Results

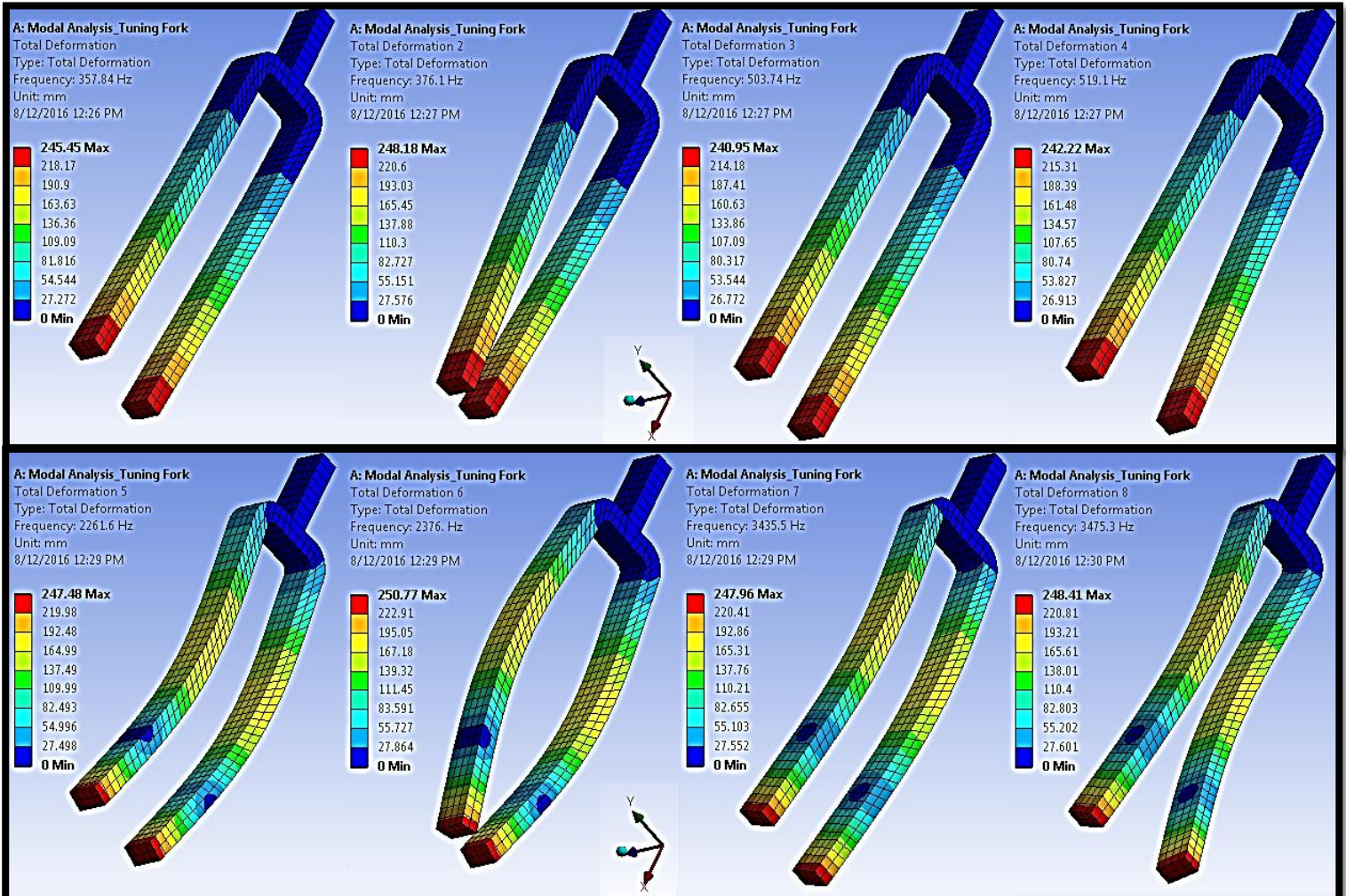

Tabular Data

Mode	Frequency [Hz]
1	357.84
2	376.1
3	503.74
4	519.1
5	2261.6
6	2376.
7	3435.5
8	3475.3

We are able to see here, all the 8 Modes that we choose for output. Also you can see how the deformation and the frequency varies. In the Tabular Data tab, there are all the frequencies from 1<sup>st</sup> Mode to 8<sup>th</sup>.

## 6.7 Modify Model

### i. Changing Material

In this section, we will define a new material to see if we have a difference in the frequency outputs. We will change the material from Structural Steel to Copper Alloy. In order to do that, we will need to assign the new material in the Engineering Data tab, let's see how to do that. Close Mechanical UI, and open Engineering Data tab.

1 Double-click on Engineering Data.

2 Click on Engineering Data Sources.

3 Highlight General Materials, and a new window will open up right below the Engineering Data Sources.

	A	B	C	D
1	Data Source		Location	Description
2	Favorites			Quick access list and default items
3	General Materials	<input type="checkbox"/>		General use material samples for use in various analyses.
4	General Non-linear Materials	<input type="checkbox"/>		General use material samples for use in non-linear analyses.
5	Explicit Materials	<input type="checkbox"/>		Material samples for use in an explicit analysis.
6	Hyperelastic Materials	<input type="checkbox"/>		Material stress-strain data samples for curve fitting.
7	Magnetic B-H Curves	<input type="checkbox"/>		B-H Curve samples specific for use in a magnetic analysis.
8	Thermal Materials	<input type="checkbox"/>		Material samples specific for use in a thermal analysis.
9	Fluid Materials	<input type="checkbox"/>		Material samples specific for use in a fluid analysis.
10	Composite Materials	<input type="checkbox"/>		Material samples specific for composite structures.

4 Locate Copper Alloy, and by clicking on the [+], you will add the new material to our study.

	A	B	C	E
1	Contents of General Materials		Add	Description
2	Material			
3	Air			General properties for air.
4	Aluminum Alloy			General aluminum alloy. Fatigue properties come from MIL-HDBK-5H, page 3-277.
5	Concrete			
6	Copper Alloy			
7	Gray Cast Iron		Add to A2: Engineering Data	

	A	B	D
1	Contents of Engineering Data		Description
2	Material		
3	Copper Alloy	<input type="checkbox"/>	
4	Structural Steel	<input type="checkbox"/>	Fatigue Data at zero mean stress comes from 1998 ASME BPV Code, Section 8, Div 2, Table 5-110.1
*	Click here to add a new material		

5 If you de-select, Engineering Data Sources, you will be able to visualize this window. You can see now our two materials.

7 Close Engineering Data Tab, and open up Mechanical UI by double-clicking on Model. A pop-up window will appear asking you if you want to re-read the Upstream Data, click Yes.

6 Now that you added the new material, we will need to go back to the Mechanical UI and assign it on our model.

⑧ When Mechanical UI loads, highlight Geometry/ Solid and get to the Details View tab.

⑨ Change the Material/ Assignment to Copper Alloy.

⑩ Right- click on Solution/ Solve.

Mode	Frequency [Hz]
1	258.44
2	271.56
3	361.87
4	372.43
5	1632.5
6	1714.8
7	2475.3
8	2501.9

⑪ We can see now in the Tabular Data tab, that the frequencies are totally different than the ones we had before. But still we are far from the desired frequency (440Hz).

ii. Changing the Dimensions

Since, changing the material did not help us get the required frequency results, we will try now and change some dimensions from our tuner and see how it affects the frequency results. Changing all the dimension would not be much of a help for us, we will modify the l=length dimension and possibly the thickness of the tuner.

We can always follow the procedure we did in Chapter\_III [section 3.8], and change the dimensions in the DesignModeler-Head back to the Mechanical UI-Update Geometry from Source-Solve and get the new result outputs.

In this section, I will introduce you a new way to make modifications in the geometry, which will be easier and faster. We will assign some parameters, and by changing those parameters we will be able to see instantly the frequency result outputs.

① Open up DesignModeler.

② Highlight Sketch1, the one located in the Extrude1 branch.

③ Choose the box [located on the left of H1]. "H1" is the length we are interested in modifying.

④ A pop up window will appear asking you to name your Parameter.

Dimension	Value
H1	100 mm
H3	20 mm
H5	5 mm
V2	5 mm
V4	2.5 mm
V6	8 mm

Parameter Name: XYPlane.H1

⑤ After giving a name to your Parameter, a "D" will appear in the box. That means that our parameter is ready.

Dimensions: 6		
<input checked="" type="checkbox"/> D H1		100 mm
<input type="checkbox"/> H3		20 mm
<input type="checkbox"/> H5		5 mm
<input type="checkbox"/> V2		5 mm
<input type="checkbox"/> V4		2.5 mm
<input type="checkbox"/> V6		8 mm

⑦ Close DesignModeler.

Details View	
Details of Extrude1	
Extrude	Extrude1
Geometry	Sketch1
Operation	Add Material
Direction Vector	None (Normal)
Direction	Normal
Extent Type	Fixed
<input checked="" type="checkbox"/> D FD1, Depth (>0)	8 mm
As Thin/Surface?	No
Merge Topology?	Yes
Geometry Selection: 1	
Sketch	Sketch1

⑥ Do the same for the thickness. Highlight Extrude1, get to the Details View, and make a parameter out of FD1, Depth.

⑧ When you get back to the Project Schematic, an 8<sup>th</sup> option must appear, the Parameters.

Project Schematic	
A	
1	Modal
2	Engineering Data ✓
3	Geometry ✓
4	Model ✓
5	Setup ✓
6	Solution ✓
7	Results ✓
8	Parameters ✓
Modal Analysis_Tuning Fork	
Parameter Set	

⑨ Now we need to make a Parameter out of the frequency. Open up Mechanical UI.

⑩ Highlight the first Total Deformation.

Outline	
Filter:	Name
Geometry	
Coordinate Systems	
Mesh	
Modal (A5)	
Pre-Stress (None)	
Analysis Settings	
Fixed Support	
Solution (A6)	
Solution Information	
Total Deformation	
Total Deformation 2	
Total Deformation 3	
Total Deformation 4	
Total Deformation 5	
Total Deformation 6	
Total Deformation 7	
Total Deformation 8	

Details of "Total Deformation"	
Scope	
Scoping Method	Geometry Selection
Geometry	All Bodies
Definition	
Type	Total Deformation
Mode	1.
Identifier	
Suppressed	No
Results	
<input type="checkbox"/> Minimum	0. mm
<input type="checkbox"/> Maximum	258.76 mm
Information	
<input checked="" type="checkbox"/> P Frequency	258.44 Hz

⑪ Open Information branch, and click on the Box located on the left of Frequency.

⑫ After completing these steps, you now have added a second parameter of Frequency, close Mechanical UI.

Project Schematic	
A	
1	Modal
2	Engineering Data ✓
3	Geometry ✓
4	Model ✓
5	Setup ✓
6	Solution ✓
7	Results ✓
8	Parameters ✓
Modal Analysis_Tuning Fork	
Parameter Set	

⑭ Open up Parameters, to see how this option works.

⑬ End result of your Modal Analysis System. You can see that the arrows are forming a circle, meaning that when you change one of the parameters we set up, the others will change also.

Table of Design Points							
	A	B	C	D	E	F	G
1	Name	P1 - XYPlane.H1	P2 - Extrude1.FD1	P3 - Total Deformation Reported Frequency	<input type="checkbox"/> Retain	Retained Data	Note
2	Units	mm	mm	Hz			
3	DP 0 (Current)	100	8	258.44	<input checked="" type="checkbox"/>	✓	
4	DP 1	90	8	⚡	<input type="checkbox"/>		
5	DP 2	80	8	⚡	<input type="checkbox"/>		
6	DP 3	50	8	⚡	<input type="checkbox"/>		
7	DP 4	100	7	⚡	<input type="checkbox"/>		
8	DP 5	100	5	⚡	<input type="checkbox"/>		
9	DP 6	80	7	⚡	<input type="checkbox"/>		
10	DP 7	80	5	⚡	<input type="checkbox"/>		
*					<input type="checkbox"/>		

16 Here you can add as many different dimension values as you like. Column B refers to the length values. Column C refers to the thickness of the tuner. Column D refers to the Frequency results.

15 When Parameters option loads, you will be able to see this window, named Table of Design Points.

17 As you can see I added 10 different values, and the only thing left to do, is to evaluate those values and acquire the frequency output results.

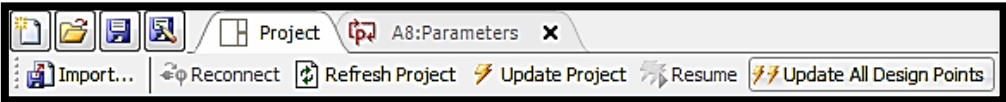

18 Go back to the Project tab, and choose Update All Design Points. This option will start solving all the Parameters you assigned one by one, without any more help from the user. This normally takes a while, and the more parameters you assign, the more time consuming this Update will be.

19 After the Update is done, head back to the A8: Parameters tab and have a look at the results. Here are mine.

Table of Design Points							
	A	B	C	D	E	F	G
1	Name	P1 - XYPlane.H1	P2 - Extrude1.FD1	P3 - Total Deformation Reported Frequency	<input type="checkbox"/> Retain	Retained Data	Note
2	Units	mm	mm	Hz			
3	DP 0 (Current)	100	8	258.44	<input checked="" type="checkbox"/>	✓	
4	DP 1	90	8	315.2	<input type="checkbox"/>		
5	DP 2	80	8	393.05	<input type="checkbox"/>		
6	DP 3	75	8	443.33	<input type="checkbox"/>		
7	DP 4	100	7	258.2	<input type="checkbox"/>		
8	DP 5	100	5	245.89	<input type="checkbox"/>		
9	DP 6	80	7	392.62	<input type="checkbox"/>		
10	DP 7	80	5	371.5	<input type="checkbox"/>		
*					<input type="checkbox"/>		

20 According to my results, our Tuning Fork, in order to be functional (A=440 Hz) must have a length dimensions equal to 75mm, and thickness of 8mm.

